

User Guide

iBypass Switches with Heartbeat™

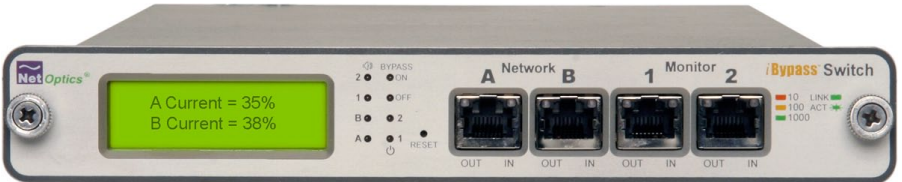

PLEASE READ THESE LEGAL NOTICES CAREFULLY.

By using a Net Optics iBypass Switch you agree to the terms and conditions of usage set forth by Net Optics, Inc.

No licenses, express or implied, are granted with respect to any of the technology described in this manual. Net Optics retains all intellectual property rights associated with the technology described in this manual. This manual is intended to assist with installing Net Optics products into your network.

Trademarks and Copyrights

© 2011 by Net Optics, Inc. Net Optics® is a registered trademark of Net Optics, Inc. iBypass™ is a trademark of Net Optics, Inc. Additional company and product names may be trademarks or registered trademarks of the individual companies and are respectfully acknowledged.

Additional Information

Net Optics, Inc. reserves the right to make changes in specifications and other information contained in this document without prior notice. Every effort has been made to ensure that the information in this document is accurate.

Contents

Chapter 1

Introduction	1
About this Guide	1
Features	1
Bypass Modes	3
Tap Mode During Bypass	5
SNMP Traps	6
Traffic Statistics	6

Chapter 2

Front Panel	7
Threshold Alarm LEDs	8
Link LEDs	8
Power LEDs	8
Reset Button	8

Chapter 3

Installing the iBypass Switch	9
Plan the Installation	9
Unpack and Inspect the iBypass Switch	10
Installing XFP or SFP Monitor Port Transceivers	10
Rack Mount the iBypass Switch (optional)	10
Connect Power to the iBypass Switch	11
Connecting to the CLI Interface	12
Configure the iBypass Switch with the CLI	13
Connect the iBypass Switch to the Network	17
Connect the Management Port to the Network	17
Connect a Monitoring Device to the iBypass Switch	18
Check the Installation	19

Chapter 4

Web Manager	20
Access Web Manager	20
Set Date and Time Window	24
Check/Change the Heartbeat Packet from Web Manager	25
Download and Install New Software	26
Set Port Parameters	28

Chapter 5

System Manager	29
Overview	29
Install System Manager	30
Explore System Manager	31
Create a System Manager Group	33
Delete a System Manager Group	33
Add Devices to a System Manager Group	34
Delete an iBypass Switch from System Manager	35
Configure an iBypass Switch from System Manager	36
View iBypass Switch Information from System Manager	39
Modify an iBypass Switch Name or Address from System Manager	42
Change a Heartbeat Packet from System Manager	42
Uninstalling System Manager	43

Appendix A

Specifications and Models	44
Specifications	44
Available Models	46

Appendix B

Command Line Interface	47
iBypass Switch CLI Syntax	47
Set Parameter Port Command	50

Chapter 1

Introduction

Thank you for choosing Net Optics 10 GigaBit Fiber, GigaBit Fiber, or 10/100/1000 iBypass Switch, the most versatile intelligent iBypass Switches available today. This guide is designed to help answer your questions and provide an installation reference.

Net Optics iBypass Switch with Heartbeat provides a permanent access port for inline network security and monitoring. The iBypass Switch automatically switches network traffic through added devices, or bypasses devices that are removed. The intelligent iBypass Switch Heartbeat provides notifications to protect network traffic against both signal and power loss on an attached device.

About this Guide

This guide describes the installation and use of the following models:

Part Number	Description
IBPO-HBSR-XFP	10 GigaBit SR iBypass Switch with Heartbeat
IBPO-HBLR-XFP	10 GigaBit LR iBypass Switch with Heartbeat
IBPO-HB50SR-XFP	10 GigaBit SR iBypass Switch with Heartbeat, 50um
IBPO-HBER-XFP	10 GigaBit ER iBypass Switch with Heartbeat
IBPO-HBLX-SFP	GigaBit LX iBypass Switch with Heartbeat
IBPO-HBSX-SFP	GigaBit SX iBypass Swith with Heartbeat
IBP-HBCU3	10/100/1000 iBypass Switch with Heartbeat

Features

Heartbeat Packet

The iBypass Switch monitors the attached device by sending a Heartbeat packet to the device. If the iBypass Switch does not receive the Heartbeat response, it automatically switches network traffic to bypass the unresponsive device—even if the device is still receiving power. The iBypass continues to send the Heartbeat, and will restore traffic flow through the device as soon as the link is restored. For special applications, you can customize the Heartbeat Packet rate from the iBypass Command Line Interface (CLI) or Web Manager GUI.

Uninterrupted Traffic

This iBypass Switch supports fail-open monitoring with any 10 GigaBit device when it shares the same power source as the device. As long as the iBypass Switch is receiving power, it will divert network traffic to attached monitoring devices. In this state, all traffic is routed directly to the monitoring device connected to the iBypass Switch.

When the iBypass Switch loses power, traffic continues to flow through the network link, but is no longer routed through the iBypass Switch. This allows network devices to be removed and replaced without network downtime. Once power is restored to the iBypass Switch, network traffic is seamlessly diverted to the monitoring device, allowing it to resume its critical functions.

Simply Plug It In

10 GigaBit iBypass Switches use XFP transceivers and GigaBit iBypass Switches use SFP transceivers. The port kit includes the cables you need to establish a secure network connection point for inline devices, and the cable to connect monitoring devices.

Bypass Detect

You can set the Monitor Ports to cycle on and off while the iBypass Switch is in Bypass ON mode in order to trigger attached devices to alarms to a management system. In Bypass Detect mode, the monitor ports will cycle through five seconds off followed by fifteen seconds on. When the iBypass Switch returns to Bypass OFF mode, the monitor ports remain on and the on/off cycle is discontinued.

Link Fault Detect

You can set the iBypass Switch to drop the remaining network link when one side of the link fails. The Link Fault Detect (LFD) feature ensures that connected devices are aware of a failure on both sides of the link.

Note

Net Optics warrants the operation of the iBypass Switches only with XFP and SFP modules supplied by Net Optics.

Passive, Secure Technology

- Fail-open monitoring with any 10 GigaBit appliance at speeds of 10 Gbps
- Protection against power, link, and application failure
- Link Fault Detect prevents undetected link failures
- XFP (10 Gigabit) and SFP (Gigabit) pluggable transceivers
- Increased reliability on critical network links
- High-speed switching with minimal insertion loss
- Custom Heartbeat packet option with configurable timeout (Heartbeat) and retries
- Dual Heartbeat tests both traffic directions (code V2.2.1 or higher)
- Tap mode during Bypass
- Fully RoHS Compliant

Ease of Use

- LED indicators show power, link, bypass and activity status
- Front-mounted connectors support easy installation and operation
- Optional 19-inch rack frame holds two iBypass Switches
- Compatible with all major manufacturers' monitoring devices, including protocol analyzers, probes, and intrusion detection/prevention systems

Support

In the event that you require our assistance, our world-class technical support is available to help you.

Support is available 24x7 for customers with a Premium Service Plan, and from 7:00 a.m. to 5:30 p.m. PST, Monday through Friday, for all other customers.

If, at any time, you have questions, please feel free to contact us by using one of the following methods:

- Phone: (408) 737-7777
- Email: ts-support@netoptics.com
- Customer Portal: <http://customer.netoptics.com/portal>

Bypass Modes

The iBypass Switch with Heartbeat bypasses attached in-line device and sends traffic straight through the network link when one of three events occurs:

- Power loss to the switch
- Link failure
- Application failure

Two LEDs on the front of the iBypass Switch indicate whether the switch is bypassing the connected appliance or not. When the Bypass ON indicator is illuminated, the iBypass Switch has not received the heartbeat packet as expected and directly connects Network Ports A and B.

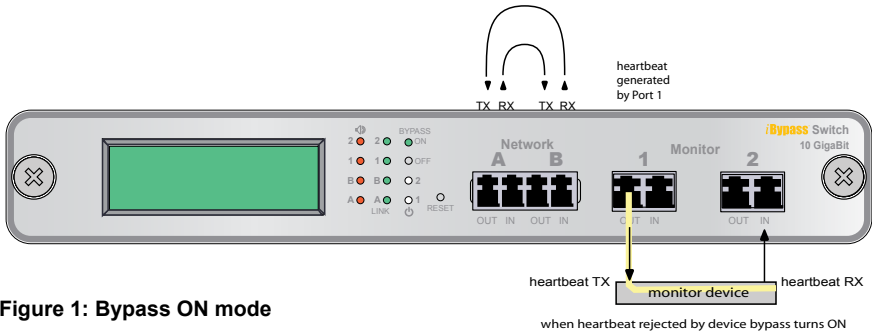

Figure 1: Bypass ON mode

When the Bypass OFF indicator is illuminated, the iBypass Switch is sending traffic through the attached in-line device. Network Port A is connected to Monitor Port 1 and Network Port B is connected to Monitor Port 2.

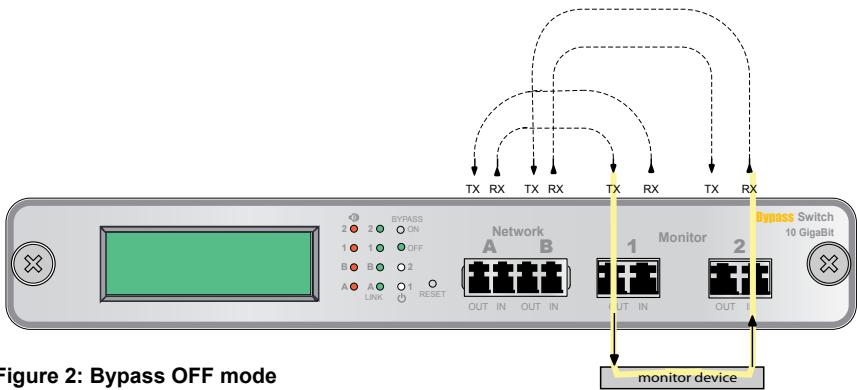

Figure 2: Bypass OFF mode

Power Loss Bypass

The iBypass Switch protects link integrity when the attached monitoring device loses power. To install the iBypass Switch for this type of protection, the switch should share the same power source as the monitoring appliance. If you are using redundant power supplies for the iBypass Switch, make sure that both monitoring devices are connected to the same power source as the iBypass Switch device.

Heartbeat Bypass

The iBypass Switch with Heartbeat protects against both physical link failure and application failure on the monitoring device. The iBypass Switch checks the path through the monitoring device by sending a packet at a predetermined rate (for example, once every millisecond from Monitor Port 1). The iBypass Switch validates the path when it receives the packet on the Monitor Port 2. If the iBypass Switch does not receive the packet as expected three times in a row (assuming the Retry count is set to 3), the iBypass Switch automatically enters Bypass ON mode. You can use the CLI or remote interfaces to change the number of the Heartbeat packets required (Retry parameter 1-255) before the iBypass Switch enters Bypass ON mode. The switch continues to send the bypass packet and will return to Bypass OFF mode the first time it receives a heartbeat packet on Monitor Port 2. The contents of the default Heartbeat packet can be seen on page 41.

Note:

Devices with software version 2.2.1 or higher have a dual Heartbeat: Heartbeat packets are transmitted from both monitor ports and received on the other port. The device goes into the Bypass ON mode if Heartbeats fail in either direction. Heartbeats must be seen in both directions in order to return to Bypass OFF mode.

Manual Bypass

In software versions earlier than V2.2.1, the iBypass Switch can be manually set to Bypass ON (Tap) mode by setting the Heartbeat Timeout parameter to 0 using the CLI (**set timeout 0**) or remote interfaces. It returns to normal operation when the Heartbeat Timeout parameter is restored to a non-zero value. No Heartbeat packets are transmitted when the iBypass Switch is in manual bypass (Tap) mode.

In software versions V2.2.1 and later, the iBypass Switch can be manually set to Bypass ON (Tap) mode by setting Tap mode using the CLI (**set mode 1**) or remote interfaces. If you do not want Heartbeat packets to appear on the monitor ports, set the Heartbeat Timeout parameter to 0. The iBypass Switch returns to normal operation when Tap mode is turned off using the CLI (**set mode 2**) or remote interfaces, AND the Heartbeat Timeout parameter is restored to a non-zero value.

Tap Mode During Bypass

Whenever the iBypass Switch is in Bypass ON mode, it operates as a full-duplex breakout Tap, copying the traffic received at Network Port A to Monitor Port 1, and traffic received at Network Port B to Monitor Port 2. This function enables the attached device to monitor network traffic out-of-band, for instance to baseline the system prior to putting the device in-line. The only difference from a normal network Tap is that Heartbeat packets continue to be transmitted (if the Switch is not in Manual Bypass mode) in order to detect when the monitoring tool comes back online.

Note:

When using the iBypass Switch as a network Tap, be sure to set the Bypass Detect Feature to "OFF" so the ports remain on constantly.

SNMP Traps

The iBypass Switch transmits SNMP traps for the following events:

- Bypass state changes
- Utilization exceeds the threshold on any port
- Any port link status changes
- Port manually disabled
- Either power supply state changes

Traffic Statistics

The iBypass Switch collects statistics about the traffic passing through each of its ports. The statistics can be viewed and cleared using any of the management interfaces. The traffic statistics collected by the iBypass Switch on each of its ports are:

- Peak traffic rate
- Time of the peak traffic
- Current bandwidth utilization
- Total number of packets
- Total number of bytes
- Number of Cyclical Redundancy Check (CRC) errors
- Number of oversize packets

Note

The traffic statistics counters are 32 bits wide, so the maximum value of each counter is 4,294,967,295. The counters roll over to 0 after the maximum count is reached. Be aware that, at 10 Gbps, the Total Bytes counter can roll over in as short a time as 3.4 seconds and the Total Packets counter in 3.7 minutes.

Chapter 2 Front Panel

The utilization data on the display is refreshed every second. Network peaks are given as a percent of utilization and reflect the highest peak recorded since the last reset. The day and time information reflects the highest peak event since reset. You can set the iBypass Switch 24-hour clock through the CLI or by using the remote manager interfaces.

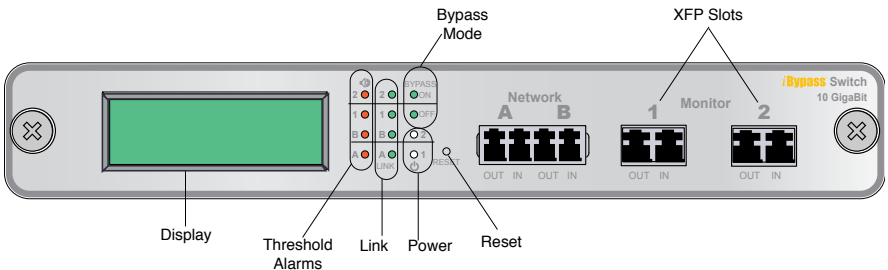

Figure 3: Front Panel of a GigaBit or 10 GigaBit iBypass Switch

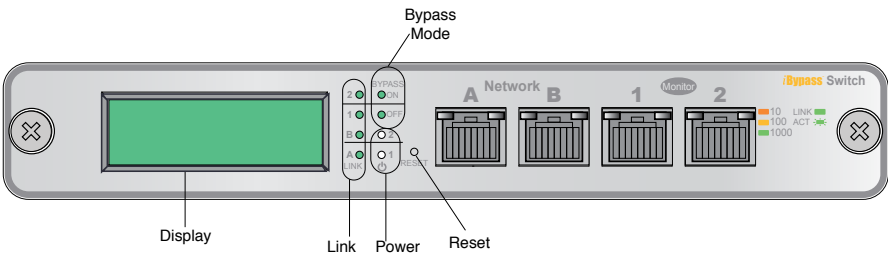

Figure 4: Front Panel of a IBP-CU3 10/100/1000 iBypass Switch

For example:

If you set the thresholds for 30% utilization on Friday and over the weekend six peaks over 30% occur, the iBypass Switch provides information only on the highest peak.

If data is not displaying as expected, check the Network Port connectors for link status and activity. Also check the status of the display command using the CLI (see *Using the Command Line Interface* in chapter 2).

Threshold Alarm LEDs

Four LEDs indicate that utilization levels have exceeded the threshold. There is one LED per port for incoming traffic on the front panel. When a Threshold Alarm LED is red, it indicates that the threshold level was exceeded for that port since the last reset. The LEDs remain illuminated until reset via the reset button or remote interfaces. (Threshold alarm LEDs are not provided on the 10/100/1000 iBypass Switch.)

Link LEDs

Four LEDs indicate link status. If a good link is established, the LED illuminates a steady green. If there is no current activity on this link, the LED flashes.

Power LEDs

If the iBypass Switch is deployed with both power supplies, both power LEDs will illuminate when connected to power. If a power LED is off, the corresponding power supply is not functioning or connected.

Reset Button

Press the Reset button to reset the traffic peak and time on the display and the Threshold Alarm LEDs. To prevent accidental resets, the Reset button is recessed from the front panel. To push the Reset button, use a thin, rigid tool such as an unbent paperclip.

Chapter 3

Installing the iBypass Switch

This chapter describes how to install and connect the iBypass Switch. The procedure for installing the iBypass Switch follows these basic steps:

- Plan the installation
- Unpack and inspect the iBypass Switch
- Install (XFP or SFP) pluggable transceivers
- Rack mount the iBypass Switch (optional)
- Connect power to the iBypass Switch
- Connect the CLI RS232 interface for configuration
- Configure the iBypass Switch default values with the CLI
- Connect the iBypass Switch to network devices
- Connect the Management Port to the network
- Connect iBypass Switch Ports to monitoring device(s)
- Check the installation

After the iBypass Switch is installed, you can remotely monitor and control the iBypass Switch from either Web Manager or System Manager.

Plan the Installation

Before you begin the installation of your iBypass Switch, determine the following:

- IP address of the iBypass Switch or, if you are deploying multiple iBypass Switches, a range of IP addresses
- Net Mask for the iBypass Switch
- IP address of the remote management console (destination for SNMP traps)
- Gateway to the remote management console

Also make sure you have a suitable location to install the iBypass Switch. For power redundancy, use two independent power sources.

Unpack and Inspect the iBypass Switch

Unpack the iBypass Switch, power supplies, and all cables that are provided. Each iBypass Switch is delivered with the following:

- 2 Power supplies
- 2 LC fiber cables (fiber models) or CAT5e cables (IBP-HBCU3 model)
- 1 RJ45 CAT5e cable
- 1 DB-9 RS232 cable
- Quick Installation Guide
- CD that contains this manual and System Manager software

You may have also purchased a panel for rack mounting the iBypass Switch, and an extended warranty. If any component is missing or damaged, contact Net Optics Customer Service immediately at +1 (408) 737-7777.

Installing XFP or SFP Monitor Port Transceivers

The XFP or SFP transceiver modules for fiber models are packaged separately. You need to remove the temporary plugs from the iBypass Switch monitor slots and insert the XFP or SFP modules into the monitor slots, as shown below, until they click into place.

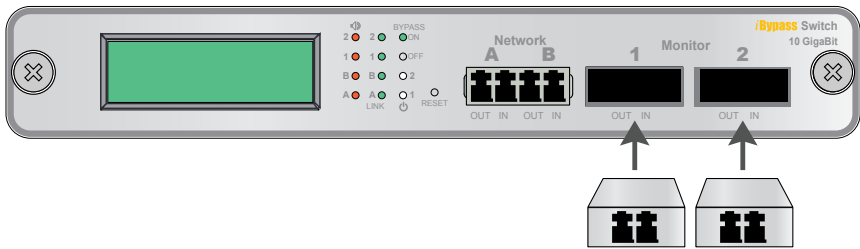

Figure 5: Insert XFP or SFP Connectors in Monitor Slots

Rack Mount the iBypass Switch (optional)

The iBypass Switch is designed for rack mounting in a two-slot, 19-inch panel. The mounting panel occupies one rack unit.

To rack mount the iBypass Switch:

1. Attach the two-slot panel to your equipment rack using the thumb screws on the panel.

2. Slide the iBypass Switch into one of the slots and secure the device by tightening the thumb screws.
3. Make sure that the rack is properly grounded.

Connect Power to the iBypass Switch

For power fault protection, the iBypass Switch has redundant power supplies. The second power supply is available to support the flow of traffic to the monitoring device in the event that the first power supply becomes unavailable. If the first power supply is unavailable, the second power supply provides all power for the iBypass Switch. Even if no power is available to the passive iBypass Switch, network traffic flows uninterrupted.

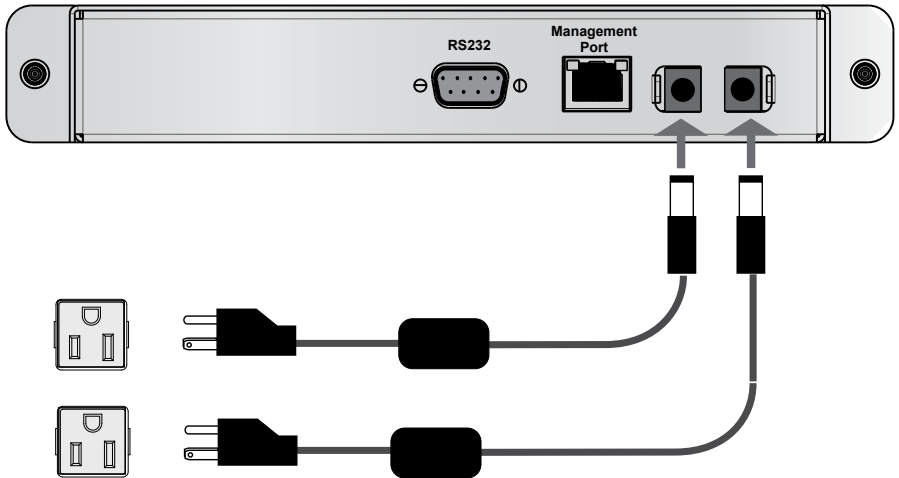

Figure 6: Connecting dual power supplies

Connect the power supplies to the back of the unit. If you plan to use redundant power, make sure that you connect the power supplies to two separate, independent power sources. The unit should now have one or both front panel Power LEDs illuminated, depending on whether you used one power cable or two.

Connecting to the CLI Interface

All configuration options, status, and statistics are accessible from the iBypass Switch Command Line Interface. You will now set a new username and password, IP address for the iBypass Switch, utilization threshold levels for Port A and B, and the current date and time. Other parameters are optional and dependent on your installation. To do this configuration, you need to connect an RS232 DB9 cable to the back of the iBypass Switch and to your computer.

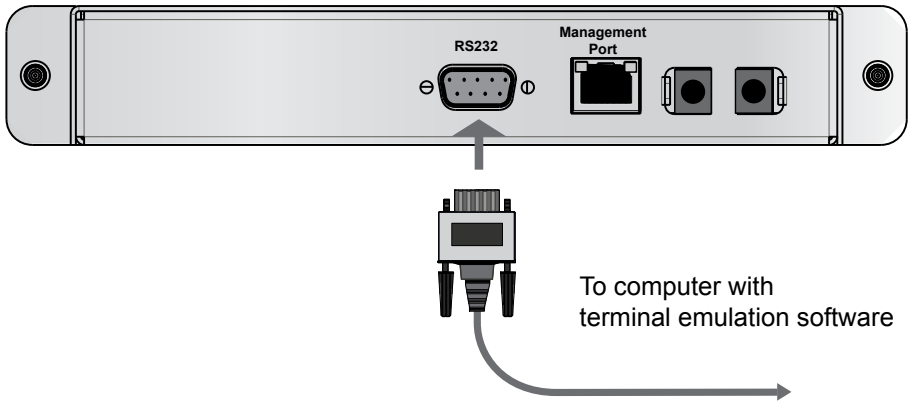

Figure 7: RS232 DB-9 connecting to computer

Your computer needs to have terminal emulation software such as HyperTerminal to access the iBypass Switch CLI via the RS232 cable..

To connect the CLI:

1. Connect a PC with terminal emulation software, such as HyperTerminal, to the iBypass Switch using the RS232 DB-9 cable supplied with the iBypass Switch.
2. Launch the terminal emulation software and set communication parameters to:

19200 baud
8 data bits
No parity
1 stop bit
No flow control

3. Power on the iBypass Switch. The Net Optics CLI banner and login prompt appear in the Terminal Emulation software (see below). The login default is **netoptics**.

```
*****
* Net Optics Command Line Interface *
*****
login: netoptics
password:
```

4. Enter the password. The default password is **netoptics**.

```
*****
* Net Optics Command Line Interface *
*****
login: netoptics
password: netoptics
```

Configure the iBypass Switch with the CLI

You should be logged into the iBypass CLI using terminal emulation software. If you are not, see the instructions on the previous page.

The default values for this iBypass Switch are:

- Management Port: **Enabled**
- IP Address: **192.168.2.100**
- Netmask: **255.255.0.0**
- Threshold Port A: **50%**
- Threshold Port B: **50%**
- Threshold Port 1: **50%**
- Threshold Port 2: **50%**
- Username: **netoptics**
- Password: **netoptics**
- Auto-negotiate: **On** (IBP-HBCU3 only)
- Port speed: **Gigabit** (IBP-HBCU3 only)

For security reasons, some parameters can only be set with the CLI. A complete list of CLI commands is in Appendix B.

You will use the CLI now to:

- Change the login and password
- Assign a new IP address
- Change utilization thresholds
- Set the date and time
- Display and check the CLI settings
- Disable and enable the Management Port

Your terminal emulator should be displaying the Net Optics prompt shown below. If it does not, follow the directions on the previous page.

```
Net Optics>
```

You can change most settings later from one of the remote manager interfaces (for more information about remote interfaces, see Chapters 4 and 5).

Change the iBypass Switch Username and Password

1. Change the username by entering the following command:

```
set username <new username>
```

2. Change the password by entering the following command:

```
set password <new password>
```

3. Record the username and password in a secure location.

Assign a New iBypass Switch IP Address

To change the iBypass Switch IP address:

Enter **set ip <new ip address>**.

Example: Enter **set ip 10.60.10.100** to set the iBypass Switch IP address to 10.60.10.100.

Web Manager and System Manager will connect to the device at this address.

Change Port Utilization Threshold Levels

1. Enter **set threshold port a <new level>** to set a percentage of available bandwidth for Port A. Exceeding this limit will trigger the alarm.

Example: Enter **set threshold port a 30** to set the alarm threshold level for traffic received on Port A to 30%.

2. Enter **set threshold port b <new level>** to set a percentage of available bandwidth for Port B. (Exceeding this limit will trigger the alarm.)

Example: Enter **set threshold port b 30** to set the alarm threshold level for traffic received on Port B to 30%.

Set the Current Date and Time

Enter **set time <mm/dd/yyyy-hh:mm:ss>** where *mm* is month, *dd* is day of the month, *yyyy* is year, *hh* is hour, *mm* is minutes of the hour, and *ss* is seconds.

Time is based on the 24-hour clock.

Display and Check Current Settings

Enter **show set**.

The CLI displays the current setting, similar to the example below.

```

Net Optics> show set
show set

      Model:                Net Optics Management System for HB Bypass
      System Time:          03/29/2011 18:25:14
      IP Address:           10.60.4.20
      Netmask: 255.0.0.0
      Manager: 192.168.0.1
      Gateway: 10.0.0.1
      Management Port: ON
      Port Parameter: 0X37
      Threshold A:          50
      Threshold B:          50
      Threshold 1:          50
      Threshold 2:          50
      Tap Mode:              OFF
      Port LFD:              OFF
      Port Detection:       OFF
      Timeout Period:       1
      Retry Number:         3
      Web Refresh Interval: 150
  
```

Use the CLI Help Command

1. Enter **Help** at the Net Optics prompt. The list of help topics is displayed.

```

Net Optics> help

*****
* Net Optics Command Line Interface *
*****

Usage: "help <variable>"

display - Toggle internet accessibility and LCD display.
echo    - Turn on or off echoing of characters.
help    - This help screen.
ping    - ping a Network IP address.
reset   - Reset options.
set     - Configure various options.
show    - Show current configurations and status.
web     - Configure web download parameter
    
```

2. To view the syntax for changing the iBypass Switch configuration parameters, enter **help set**.

```

Net Optics> help set
help set

Usage: "set <variable> <value>"
      (type help set <variable> for specific info)

<variable> <value>
community <op> <comm>    - set <read,write> <community> string
detection <on|off>        - bypass detection
gateway <d.d.d.d>         - IP address of Default Gateway
hbpacket <xx-xx-xx ...>  - Heartbeat Packet contents (128 bytes max)
ip <d.d.d.d>              - IP address of the device
lfd <on|off>              - link fault detection
manager <d.d.d.d>        - IP address of the SNMP manager
mode <1|2>                - TAP mode
netmask <d.d.d.d>         - Network Mask of the device
parameter port <parameter> - see "help set parameter port"
password <password>      - password
retry <1-255>            - Number of missed Heartbeats for Bypass ON
timeout <0-255>          - Heartbeat timeout period in sec: 0 forces
Bypass ON
username <name>          - username
threshold port <A|B|1|2> - <0-100> - Utilization Threshold for port in %
time <mm/dd/yyyy-hh:mm:ss> - Current Date and Time
web-refresh <interval>   - web refresh interval in seconds

Net Optics>
    
```

3. Repeat with the variable of interest to view the syntax for all commands available from the CLI. For more information about CLI commands, see Appendix B.

Do not disconnect the DB9 cable yet from the RS232 port. You will use it once more to turn the iBypass Switch display on and off.

Connect the iBypass Switch to the Network

To connect the iBypass Switch to the network:

1. Connect Network Port A to the appropriate switch, server or router using an LC type fiber cable or CAT5e copper cable.
2. Connect Network Port B to the appropriate switch, server or router using an LC type fiber cable or CAT5e copper cable.

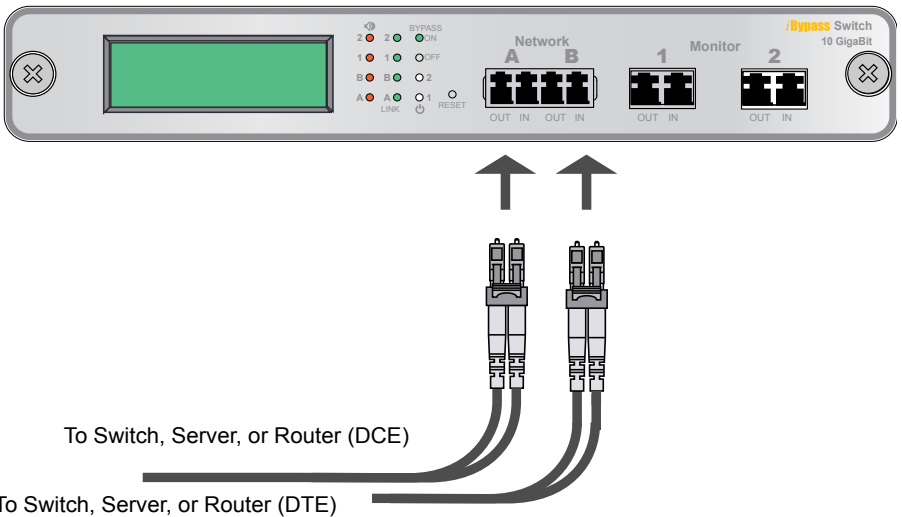

Figure 8: Connect the iBypass Switch to the Network

Connect the Management Port to the Network

To use either of the remote interfaces you must connect the Management Port on the back of the unit to the network.

To connect the Management Port:

1. Connect a CAT5e cable to the Management Port as shown in the following figure.
2. Connect the other end to a network switch or hub.

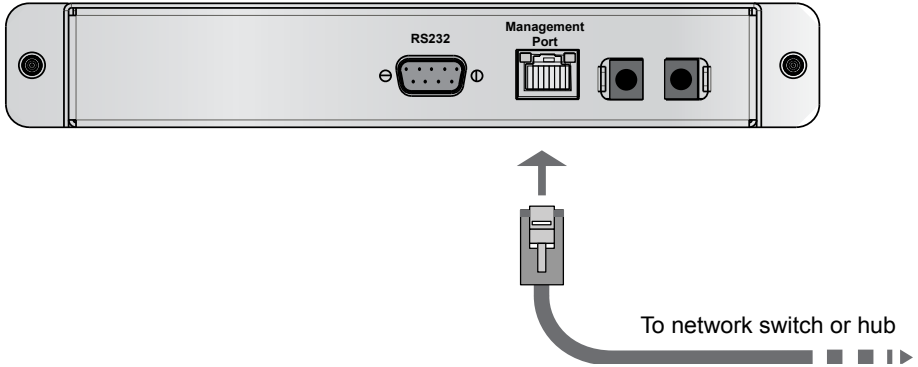

Figure 9: Connecting the Management Port

Disable, Enable and Check the Management Port

The CLI **display** command toggles the display on and off. From the terminal emulation software, do the following:

1. Enter **show display** to view the current setting. The default value is ON.
2. Enter **display**. Now look at the front of the iBypass Switch. Access from the Management Port is blocked and the iBypass Switch front panel does not display utilization or peak information.
3. Enter **display** again to restore the display and remote interfaces.

Connect a Monitoring Device to the iBypass Switch

The iBypass Switch is delivered with two monitor cables for monitoring device installation. Connect the cables to the monitoring device.

1. Connect Monitor Port 1 to the appropriate port on the monitoring device using the LC type fiber cable or CAT5e copper cable.
2. Connect Monitor Port 2 to the appropriate port on the monitoring device using the LC type fiber cable or CAT5e copper cable.

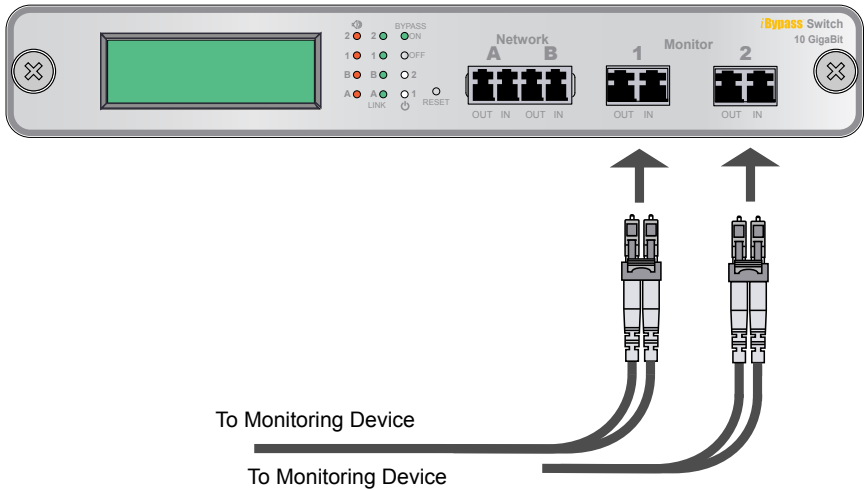

Figure 10: Connecting the Monitoring Devices

Check the Installation

You have connected the iBypass Switch to the network, to the monitoring device and to power. It should be functioning correctly now. Check the status of the following:

- Check that at least one power LED is illuminated.
- Check the link status LEDs located on the front panel to verify that traffic is passing through the switch.
- Check the display for utilization and peak information.
- Verify that the monitoring device is receiving traffic from the iBypass Switch.
- Verify that the Management Port is functional by typing the iBypass Switch's IP address in your Web browser. Net Optics' Web Manager should appear. If it does not, check the Management Port cables and connections and verify that the Display option in the CLI is set to ON.

Chapter 4

Web Manager

This chapter describes how to monitor and control individual iBypass Switches using Web Manager. The following topics are covered:

- Accessing Web Manager
- Viewing iBypass Switch Status
- Controlling iBypass Switch Connections
- Using the iBypass Switch Web Manager

The Web Manager browser-based interface allows you to change configuration settings, view status, and to control which Network ports are connected to the monitoring devices.

Note:

To access Web Manager, **Display** must be set to ON from the CLI. For more information, see *Using the Command Line Interface* in Chapter 2.

Access Web Manager

Web Manager is a browser-based interface that provides access to any iBypass Switch with an IP address. Web Manager supports all common browsers.

To access Web Manager:

1. Open an Internet browser on your computer.
2. Enter the iBypass Switch IP address in the URL. The default IP address is 192.168.2.100. Web Manager displays, as shown in the following figure.

Web Manager for HB Bypass

Bypass System Status

System Status	<input type="text" value="UP"/>	Bypass Model	<input type="text" value="10G HEART BEAT BYPASS"/>
Port A Link Status	<input type="text" value="DOWN"/>	Port B Link Status	<input type="text" value="DOWN"/>
Port 1 Link Status	<input type="text" value="UP"/>	Port 2 Link Status	<input type="text" value="UP"/>
Port A Port Speed	<input type="text" value="UNKNOWN"/>	Port B Port Speed	<input type="text" value="UNKNOWN"/>
Port 1 Port Speed	<input type="text" value="UNKNOWN"/>	Port 2 Port Speed	<input type="text" value="UNKNOWN"/>
Power Supply 1 Status	<input type="text" value="OFF"/>	Power Supply 2 Status	<input type="text" value="ON"/>
Bypass State	<input type="text" value="OUT"/>	Software Version	<input type="text" value="10G_BP_V2.0.1"/>

Bypass Port A Statistics

Port A Peak Rate (%)	<input type="text" value="0"/>
Port A Peak Date & Time	<input type="text" value="-----"/>
Port A Current Utilization Rate (%)	<input type="text" value="0"/>
Port A Total Packets	<input type="text" value="0"/>
Port A Total Bytes	<input type="text" value="0"/>
Port A CRC Errors	<input type="text" value="0"/>
Port A Collision Packets	<input type="text" value="0"/>
Port A Oversize Packets	<input type="text" value="0"/>
Port A Undersize Packets	<input type="text" value="0"/>

Bypass Port B Statistics

Port B Peak Rate (%)	<input type="text" value="0"/>
Port B Peak Date & Time	<input type="text" value="-----"/>
Port B Current Utilization Rate (%)	<input type="text" value="0"/>
Port B Total Packets	<input type="text" value="0"/>
Port B Total Bytes	<input type="text" value="0"/>
Port B CRC Errors	<input type="text" value="0"/>
Port B Collision Packets	<input type="text" value="0"/>
Port B Oversize Packets	<input type="text" value="0"/>
Port B Undersize Packets	<input type="text" value="0"/>

Bypass Port 1 Statistics

Port 1 Peak Rate (%)	<input type="text" value="0"/>
Port 1 Peak Date & Time	<input type="text" value="-----"/>
Port 1 Current Utilization Rate (%)	<input type="text" value="0"/>
Port 1 Total Packets	<input type="text" value="18"/>
Port 1 Total Bytes	<input type="text" value="1404"/>
Port 1 CRC Errors	<input type="text" value="0"/>
Port 1 Collision Packets	<input type="text" value="0"/>
Port 1 Oversize Packets	<input type="text" value="0"/>
Port 1 Undersize Packets	<input type="text" value="0"/>

Bypass Port 2 Statistics

Port 2 Peak Rate (%)	<input type="text" value="0"/>
Port 2 Peak Date & Time	<input type="text" value="-----"/>
Port 2 Current Utilization Rate (%)	<input type="text" value="0"/>
Port 2 Total Packets	<input type="text" value="18"/>
Port 2 Total Bytes	<input type="text" value="1404"/>
Port 2 CRC Errors	<input type="text" value="0"/>
Port 2 Collision Packets	<input type="text" value="0"/>
Port 2 Oversize Packets	<input type="text" value="0"/>
Port 2 Undersize Packets	<input type="text" value="0"/>

Bypass Configuration

IP Address	<input type="text" value="10.60.4.21"/>	Manager IP Address	<input type="text" value="192.168.0.1"/>
Net Mask	<input type="text" value="255.0.0.0"/>	Gateway IP Address	<input type="text" value="10.0.0.1"/>
Snmp Read Community	<input type="text" value="public"/>	Snmp Write Community	<input type="text" value="private"/>
Port Enable	<input type="text" value="Enable"/>		
Port A Utilization Threshold (%)	<input type="text" value="50"/>	Port B Utilization Threshold (%)	<input type="text" value="50"/>
Port 1 Utilization Threshold (%)	<input type="text" value="50"/>	Port 2 Utilization Threshold (%)	<input type="text" value="50"/>
Reset Port A Peak Rate	<input type="text" value="No"/>	Reset Port B Peak Rate	<input type="text" value="No"/>
Reset Port 1 Peak Rate	<input type="text" value="No"/>	Reset Port 2 Peak Rate	<input type="text" value="No"/>
Reset Port A Statistics	<input type="text" value="No"/>	Reset Port B Statistics	<input type="text" value="No"/>
Reset Port 1 Statistics	<input type="text" value="No"/>	Reset Port 2 Statistics	<input type="text" value="No"/>
Enable LFD	<input type="text" value="Off"/>	Enable Detection	<input type="text" value="Off"/>
Heart Beat Timeout Period (ms)	<input type="text" value="100"/>	Heart Beat Retries	<input type="text" value="3"/>
Tap Mode	<input type="text" value="Off"/>	Web Refresh Interval (s)	<input type="text" value="150"/>

Figure 11: Web Manager main screen

3. Change any Configuration fields. The following table describes the fields on the Web Manager window. You cannot change the Status or Statistics fields; they are read-only.

Field Name	Description
Bypass System Status	
System Status	Status of the iBypass, UP or DOWN
Link Status	Status of the port Link, UP or DOWN
Port Speed	Speed for the port
Power Supply Status	Status of the power supply, ON or OFF for this power supply
Bypass State	Indicates the bypass state, ON or OFF
Bypass Model	Indicates the iBypass model number.
Bypass Port Statistics—Port A, Port B, Port 1, Port 2 (Four screen sections)	
Peak Rate	Peak traffic rate on the port
Peak Date and Time	Time of the peak traffic, formatted as: mm/dd/yyyy hh:mm:ss
Current Utilization Rate %	The current utilization rate on port
Total Packets	The total number of packets traversing this port since the last device reset.
Total Bytes	The total number of bytes traversing this port since the last device reset.
CRC Errors	The number of Cyclical Redundancy Check errors on this port since the last device reset.
Collision Packets	The total number of link collisions seen by this port since the last device reset.
Oversize Packets	The total number of oversize packets traversing this port since the last device reset.
Undersize Packets	The total number of undersize packets traversing this port since the last device reset.
Bypass Configuration	
IP Address	IP Address for the iBypass Switch nnn.nnn.nnn.nnn. When you change the IP address, Web Manger lose its connection with the device; type the new address into the browser's address bar to connect again.
Net Mask	Netmask for iBypass Switch subnet nnn.nnn.nnn.nnn.

Field Name	Description
Manager IP Address	IP Address for the SNMP Manager nnn.nnn.nnn.nnn.
Gateway IP Address	IP Address for the default Gateway nnn.nnn.nnn.nnn.
SNMP Read Community	SNMP community string controlling MIB GET and WALK access; 3 to 31 characters, no embedded spaces.
SNMP Write Community	SNMP community string controlling MIB SET access; 3 to 31 characters, no embedded spaces.
Port Utilization Threshold (%)	Percent utilization of Port A, Port B, Port 1, Port 2 (separate parameter for each port).
Reset Peak Rate	<p>Reset (toggle Yes/No) the rate of peak usage on Port A, Port B, Port 1, Port 2 (separate control for each port). The Peak Rate is a traffic measurement during peak time. The Net Optics iBypass Web Manager will capture the highest peak rate and time, and then display them in the Statistics section.</p> <p>Assume that these peaks occurred:</p> <p>8:00 AM = 1%; 9:00 AM = 2%; 10:00 AM = 50%; 11:00 AM = 15%; 12:00 AM = 20%; 1:00 PM = 30%; 2:00 PM = 40%; 3:00 PM = 30%; 4:00 PM = 20%; 5:00 PM = 60%.</p> <p>In the Status window, at 10 AM, 50% was the Peak Rate and the display remained that way until 5 PM if no reset was done. If a reset was done at 11 AM, then the Peak Rate changed to 20% at noon, then 30% at 3 PM, then 40% at 2 PM, and then 60% at 5 PM.</p>
Reset Statistics	Reset (toggle YES/NO) the statistics of Port A, Port B, Port 1, Port 2 (separate control for each port).
Enable LFD	Enable/Disable Link Fault Detection (LFD). When LFD is enabled, if one network link goes down, the other link is automatically downed to propagate the condition.

Field Name	Description
Heartbeat Timeout Period(s)	Time between sending Heartbeat Packets. On 10 GigaBit models, the time is in milliseconds and the default value is 100. On other models, the time is in seconds and the default value is 1. If this parameter is set to 0, the Switch is forced into Bypass ON mode. In software earlier than V2.2.1, it also forces the device into Bypass ON (Tap) mode.
Enable Detection	Turn Bypass Detect ON and OFF.
Heartbeat Retries	Number of heartbeats that do not come back from a device before an iBypass unit stops sending traffic through that monitoring device; the default is 3. Heartbeat packets continue to be sent and if one comes back from the attached device, traffic flow to the device resumes.
Tap Mode (Software V2.2.1 or later)	Select ON to force the device into Tap (Bypass ON) mode (also set Heartbeat Timeout Period to 0 if you don't want Heartbeat packets on the monitor ports); select OFF for normal operation.
Web Refresh Interval	Number of seconds (from 20 to 900) between automatic reloads of the Web Manager page.

4. Save changes to the iBypass Switch by clicking **Submit Changes** at the bottom of the page.
5. To update the display, click your browser's refresh button.

The following sections explain the command buttons at the bottom of the Web Manager window.

Set Date and Time Window

Use the Set Date and Time window to set the current date and time.

1. Click **Set Date & Time** on the main window to see the Date & Time window.

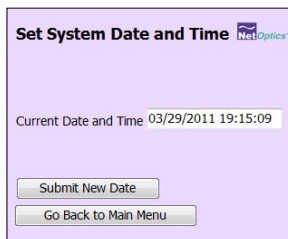

2. In the Current Date and Time text entry box type new values.
Be sure to retain the proper mm/dd/yyyy hh:mm:ss format.
3. Click **Submit New Date** to save the changes.
4. Click **Go Back to Main Menu** to return to the main Web Manager window.

Check/Change the Heartbeat Packet from Web Manager

Use the Heartbeat window to view hexadecimal information about the current Heartbeat packet or to edit the Net Optics Heartbeat packet and create your own customized Heartbeat packets (one for each monitored device). You can do this from Web Manager or System Manager.

To view the Heartbeat packet:

1. Click **Check HB Packet**. The Display Heartbeat Packet window appears.

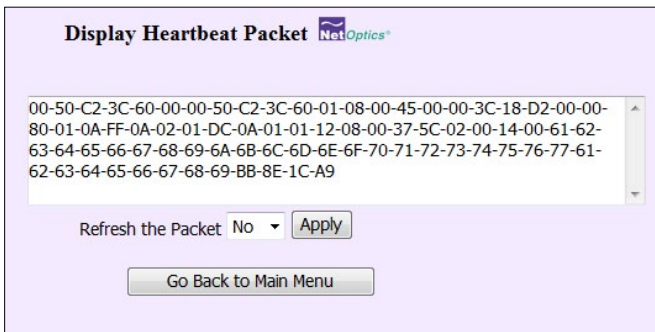

2. Select **Yes** and click **Apply**. The Heartbeat packet contents are refreshed.
3. Click **Go Back to Main Menu** to return to the main Web Manager window.

To change the Heartbeat packet:

1. Click **Edit HB Packet**. The Edit Heartbeat Packet window appears.

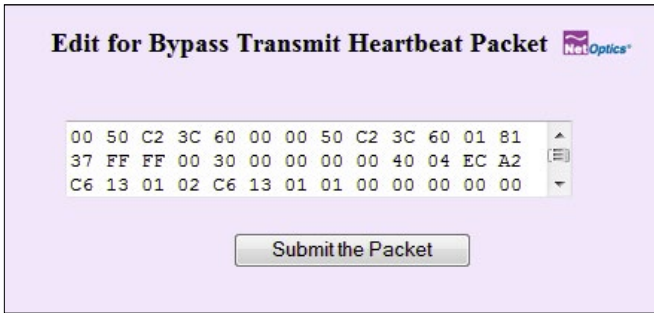

2. Change the hexadecimal values; be sure to adhere to IP address and MAC address conventions and include correct CRC bytes at the end of the packet.
3. Click **Submit the Packet** to save the changes.
4. Click **Go Back to Main Menu** to return to the main Web Manager window.

Note: The default Heartbeat packet is:

Packet Contents (Hex) -----	Description -----
00 50 C2 3C 60 00	MAC DA Net Optics
00 50 C2 3C 60 01	MAC SA Net Optics
08 00	Packet Type IP
45 00 00 3C 18 D2 00 00	
80 01 0A FF 0A 02 01 DC	
0A 01 01 12 08 00 37 5C	
02 00 14 00 61 62 63 64	
65 66 67 68 69 6A 6B 6C	
6D 6E 6F 70 71 72 73 74	
75 76 77 61 62 63 64 65	
66 67 68 69	
B8 8E 1C A9	CRC

Download and Install New Software

Use the Software Download window to download and install new software into the iBypass Switch. You can find software release information in the [Net Optics Customer Portal](#).

To download and install new iBypass Switch software:

1. Click **SW Download**. The Software Download window appears.

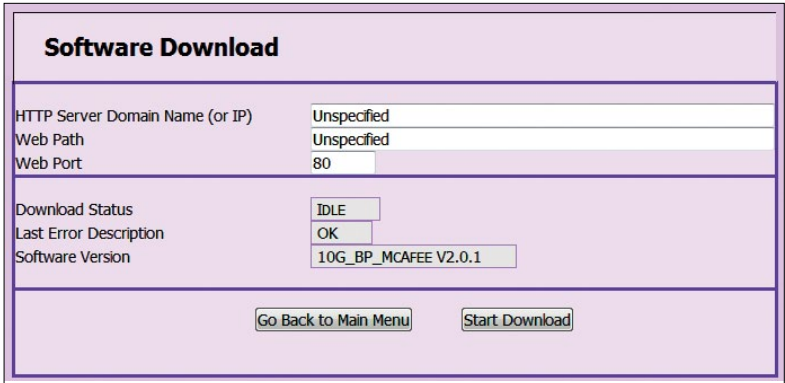

Software Download	
HTTP Server Domain Name (or IP)	Unspecified
Web Path	Unspecified
Web Port	80
Download Status	IDLE
Last Error Description	OK
Software Version	10G_BP_MCAFEES V2.0.1
<input type="button" value="Go Back to Main Menu"/> <input type="button" value="Start Download"/>	

2. Type the URL or IP address of the software download server (HTTP protocol) into the **HTTP Server Domain Name (or IP)** box.
3. Type the name of the new software image file into the **Web File** box.
4. Type the port number into the **Web Port** box if you want to use a port other than the standard HTTP port 80.
5. Double-check your entries and then click **Start Download**. The download progress is indicated in the **Download Status** box and the version number of the downloaded software image file is shown in the **Software Version** box.
6. Click **Go Back to Main Menu** to return to the main Web Manager window.

Tips!

See the Technical Note **Upgrading iTap and iBypass Software Using HFS** for instructions for setting up a Web File Server for downloading software to the iBypass Switch.

Software download through Web Manager and SNMP can be disabled for security purposes using the CLI command **remote-download off**. The default setting is **remote-download on**.

Set Port Parameters

Use the Port Settings window to enable and disable the ports, and to select whether the port auto-negotiates for link speed and duplex mode, or select a fixed speed and duplex setting. Speed selection is only available on the 10/100/1000 iBypass Switch.

All four ports are always set to the same mode. They must be the same in order to pass traffic successfully.

To set the port parameters:

1. Click **Set Port Parameters**. The Port Settings window appears.

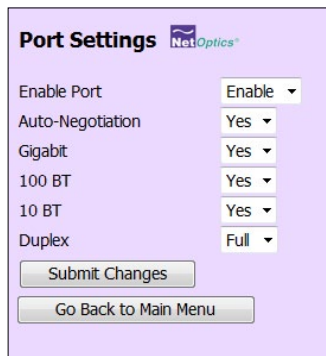

Setting	Value
Enable Port	Enable
Auto-Negotiation	Yes
Gigabit	Yes
100 BT	Yes
10 BT	Yes
Duplex	Full

Buttons: Submit Changes, Go Back to Main Menu

2. Select **Enable** or **Disable** to bring the link up or down.
3. Select **Yes** to enable link autonegotiation or **No** for fixed settings.
4. Select the link speed if it is a 10/100/1000 iBypass Switch, Gigabit for 1000 Mbps, 100 BT for 100 Mbps, or 10 BT for 10 Mbps. You must select **Yes** for one speed and **No** for the other two.
5. Select **Full** or **Half** for the duplex mode.
6. Double-check your entries and then click **Submit Changes**. All four ports are set to the selected mode.
7. Click **Go Back to Main Menu** to return to the main Web Manager window.

Chapter 5

System Manager

Overview

This chapter describes how to install and use the Net Optics System Manager. Use the System Manager to change system settings, to view system status, and retrieve data from configured Net Optics iBypass Switch devices. The following topics are covered:

- Install System Manager
- Explore System Manager
- Create a System Manager Group
- Delete a System Manager Group
- Add iBypass Switches to a Group
- Delete an iBypass Switch
- Configure an iBypass Switch
- View iBypass Switch Information
- Change a Heartbeat Packet from System Manager

Install System Manager

The executable installation file for System Manager is distributed on the CD included with the iBypass Switch.

To install System Manger:

1. Locate **Setup.exe** on the CD and double click it. The License Agreement appears.

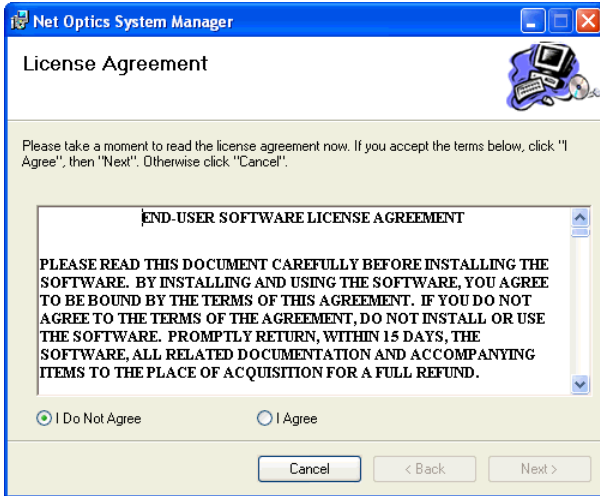

2. After reading the agreement, select **I Agree** and click **Next** to install System Manager. The Welcome dialog appears.
3. Click **Next**. The Select Installation Folder dialog box appears.
4. To install in the default folder, select the default path in the **Folder:** text box. To install in a different location, either type the path in the **Folder:** text box or click **Browse** to find another location.
5. To check the space available for System Manager on the selected drive, click **Disk Cost**.
6. To limit access to System Manager to the current user of the PC, select **Just Me**. To allow access to any user logged into the PC, select **Everyone**.
7. Click **Next**. The Confirm Installation dialog displays.

8. Click **Next** to continue with the installation. The Progress dialog displays.

To stop the installation, click **Cancel**. When the installation is complete, the Installation Complete dialog box appears.

9. Click **Close**. System Manager is now installed on your computer and a Net Optics shortcut icon has been placed onto your desktop.

Explore System Manager

This section explains the features and functions of System Manager. With System Manager you can:

- Create iBypass Switch groups
- Add and delete iBypass Switches from the system
- Remotely configure iBypass Switches
- View traffic utilization and peaks
- View traffic statistics

NOTE

In order to access an iBypass Switch with System Manager, the **Display** option must be set to ON in the CLI. For more information, see *Using the Command Line Interface* in Chapter 2.

To access System Manager:

1. Double-click the System Manager icon on your PC desktop. The login box appears.



2. Log in with the default User Name **netoptics** and Password **netoptics**. The initial System Manager window appears.

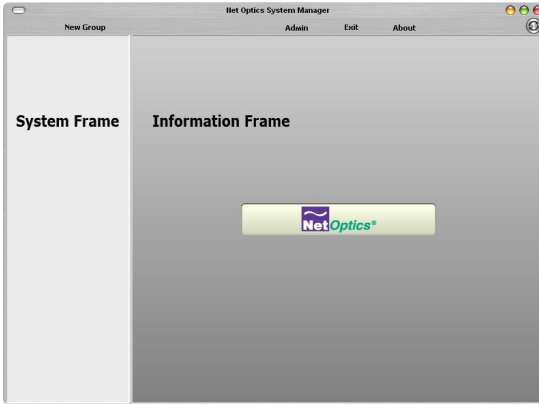

A new System Manager does not yet show any Net Optics units. The **System Frame** portion of the window (left side) displays iBypass Switches and Groups as you add them to the system. The **Information Frame** portion of the window (right side) displays Status, Configuration, and Control information for the selected unit.

Tip!

To use pop-up menu shortcuts, click your right mouse button in the System Frame.

Using the Toolbar

The following figure shows the System Manager toolbar.

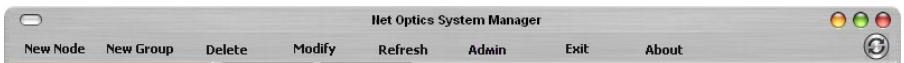

The table below describes the icons found on the toolbar.

Tool	Description
New Device	Add devices to a group
New Group	Create an iBypass Switch group
Delete	Delete devices from the system
Modify	Change the device name, IP address, model, and add notes
Refresh	Refresh the data display

Tool	Description
Admin	Change username/password
Exit	Close Net Optics System Manager
About	View information about System Manager

Create a System Manager Group

Organize iBypass Switches or other Net Optics devices into groups for quick access. Devices must belong to a group. If you add an iBypass Switch when there is no group, a group is created automatically.

To create an iBypass Switch group:

1. Click **New Group** in the toolbar. A new group bar appears in the System Frame as shown in the following figure.



2. Either accept the default group name or edit it by typing the new name and pressing **Enter**.

Delete a System Manager Group

You can delete a group; however, all devices within that group will also be deleted from System Manager.

Note:

Deleting an iBypass Switch from System Manager does not affect the current operating status of the iBypass Switch. The iBypass Switch continues to pass traffic from the Network ports to the Monitor Ports. However, you will not have visibility from System Manager unless it is added back in.

To delete a group:

1. Right-click the group that you want to delete.
2. Select **Delete** from the pop-up menu. The group and all associated devices are deleted from System Manager.

Add Devices to a System Manager Group

To configure and control iBypass Switches with System Manager, you must add each iBypass Switch to a group. Once you have added an iBypass Switch, you can configure, modify, and delete it from System Manager.

Note:

The iBypass Switch must be connected to the network as described in Chapter 2 before it can be added to System Manager.

To add an iBypass Switch to the system:

1. Select the group where the iBypass Switch will be added.
2. Click **New Device** in the toolbar. The **New Device** dialog box appears.

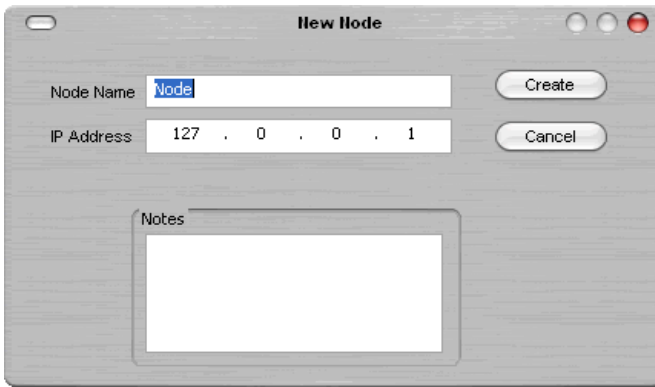

3. Enter a name for the iBypass Switch in the **Node Name** text box. Each Node Name in the system must be unique.
4. Enter the IP address of the iBypass Switch in the **IP Address** text box. The IP address must be unique on the network.
5. Enter any relevant information about the iBypass Switch in the **Notes** text box.

- Check your settings and click **Create**. The iBypass Switch appears in the system frame.

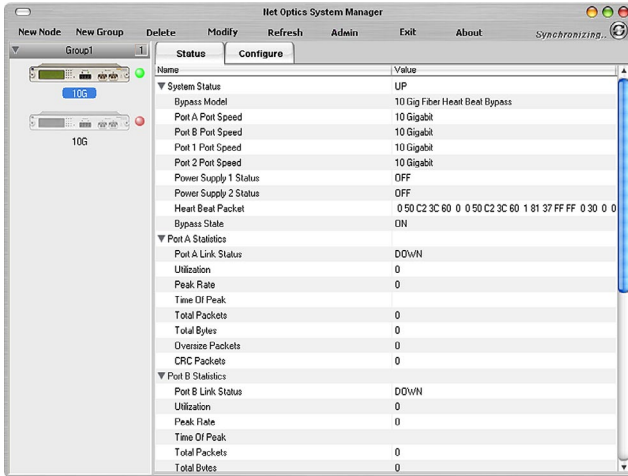

The indicator to the right of the iBypass Switch picture blinks green when the iBypass Switch is functioning normally. If there is an alarm condition on the iBypass Switch, the indicator blinks red. If System Manager cannot communicate with the iBypass Switch, the switch graphic is grayed. Check that the iBypass Switch is connected to the network and verify the configuration information.

Repeat Steps 1-6 for each iBypass Switch you are adding to System Manager.

Tip!

To change the display order of iBypass Switches, click and drag them into the desired order.

Delete an iBypass Switch from System Manager

You can delete an iBypass Switch from System Manager when you remove an iBypass Switch from your network. If you have removed an iBypass Switch from the network, System Manager continues to poll the iBypass Switch IP address for data until you delete the iBypass Switch from System Manager.

To delete an iBypass Switch from System Manager:

- Select the device you want to delete by clicking its icon.

2. Click **Delete** in the toolbar. A confirmation dialog box appears.
3. Click **Yes** to delete the iBypass Switch from System Manager.

Configure an iBypass Switch from System Manager

Set the configuration parameters of an added iBypass Switch from the **Configure** tab.

To configure an iBypass Switch:

1. Click the icon of the iBypass Switch you want to configure.
2. Click the **Configure** tab.

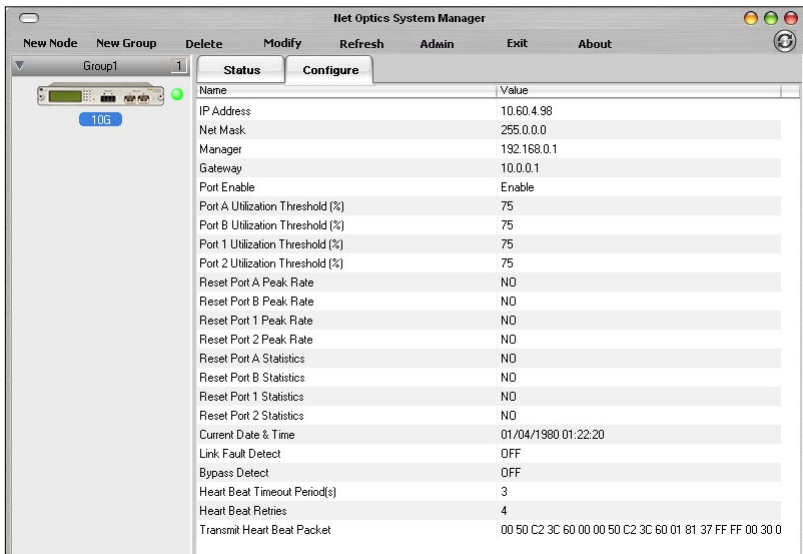

3. Click the value field for the parameter you want to configure.
4. Select an option from the drop-down list or enter a new value from your keyboard.

The table on the following page describes the iBypass Switch options on the **Configure** Tab.

iBypass Switch Configure Options

Field Name	Description
IP Address	IP address of the iBypass Switch; the default IP address is 10.60.0.123. Change the IP address by typing a new one in the box. When you change the IP address, System Manager will lose its connection with the device until you put the new address in the device in the System Frame.
Netmask	The netmask; the default netmask is 255.255.0.0. Change the netmask by typing a new one in the box.
Manager	IP address of either the host PC running System Manager over a WAN or the third-party SNMP management tool. Change the IP address by typing a new one in the box.
Gateway IP Address	IP address of the current WAN gateway. Change the gateway address by typing a new one in the box.
Port Enable	ENABLE/DISABLE the monitor ports.
Port A Utilization Threshold	Percentage level at which this port use triggers an alarm; as default the Port A alarm is triggered when Port A exceeds 50% utilization.
Port B Utilization Threshold	Percentage level at which this port use triggers an alarm; as default the Port B alarm is triggered when Port B exceeds 50% utilization.
Port 1 Utilization Threshold	Percentage level at which this port use triggers an alarm; as default the Port 1 alarm is triggered when Port 1 exceeds 50% utilization.
Port 2 Utilization Threshold	Percentage level at which this port use triggers an alarm; as default the Port 2 alarm is triggered when Port 2 exceeds 50% utilization.
Reset Port A Peak Rate	This value is NO unless you change it to YES. If you set it to YES, as soon as the port reset is complete, it returns to NO.
Reset Port B Peak Rate	This value is NO unless you change it to YES. If you set it to YES, as soon as the port reset is complete, it returns to NO.
Reset Port 1 Peak Rate	This value is NO unless you change it to YES. If you set it to YES, as soon as the port reset is complete, it returns to NO.
Reset Port 2 Peak Rate	This value is NO unless you change it to YES. If you set it to YES, as soon as the port reset is complete, it returns to NO.

Field Name	Description
Reset Port A Statistics	This value is NO unless you change it to YES. If you set it to YES, as soon as the port reset is complete, it returns to NO.
Reset Port B Statistics	This value is NO unless you change it to YES. If you set it to YES, as soon as the port reset is complete, it returns to NO.
Reset Port 1 Statistics	This value is NO unless you change it to YES. If you set it to YES, as soon as the port reset is complete, it returns to NO.
Reset Port 2 Statistics	This value is NO unless you change it to YES. If you set it to YES, as soon as the port reset is complete, it returns to NO.
Current Date & Time	Click the existing date and adjust it with the up and down arrows.
Link Fault Detect	Turn Link Fault Detection (LFD) ON or OFF. When LFD is ON, if one network link goes down, the other link is automatically downed to propagate the condition.
Bypass Detect	Turn Bypass Detect ON or OFF. In most environments, Bypass Detect should be OFF.
Heartbeat Timeout Period(s)	Time between sending Heartbeat Packets. If this parameter is set to 0, the Switch is forced into Bypass ON mode. On 10 GigaBit models, the time is in milliseconds and the default value is 100. On other models, the time is in seconds and the default value is 1.
Heartbeat Retries	Number of heartbeats that do not come back from a device before an iBypass unit stops sending traffic through that monitoring device; the default is 3. Heartbeat packets continue to be sent and if one comes back from the attached device, traffic flow to the device resumes.
Transmit Heartbeat Packet	View or change this heartbeat packet. The default is 00 05 c2 3c 60 00 00 50 c2 3c 60 01 08 00

The new configuration parameters take effect the next time System Manager polls the iBypass Switch. If System Manager detects a change when it polls, a circled arrow appears next to the value until the next polling.

View iBypass Switch Information from System Manager

System Manager allows you to view the current iBypass Switch configuration information, including the Monitor Port connections.

To view iBypass Switch information:

1. Click the image of the iBypass Switch you want to view in the System Frame.

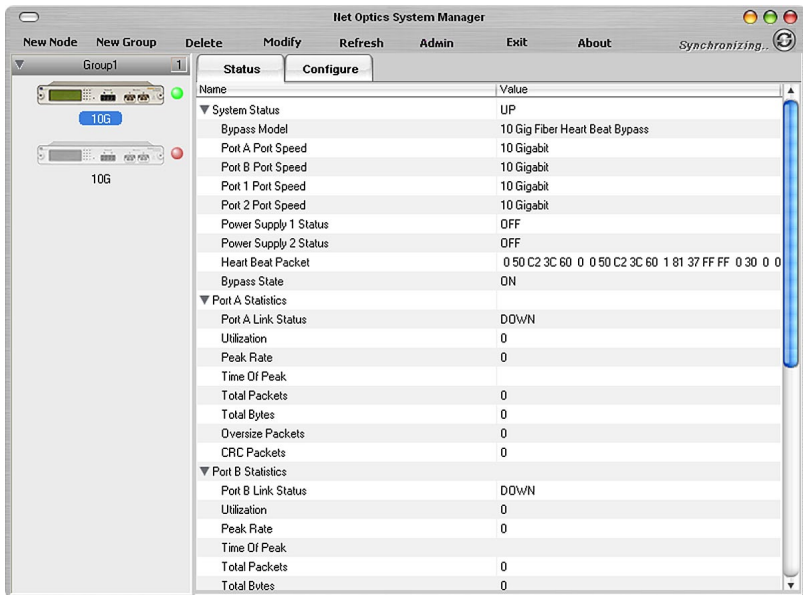

The Status tab is a read-only list of information from the iBypass Switch. Use the scroll bar and arrows to view the entire list if necessary.

TIP!

Fields that have been updated since the last refresh display with a circle and arrow just to the left of the value field.

The table on the following page describes the status fields.

iBypass Switch Status Fields

Field	Description
System Status	UP/DOWN
Bypass Model	Fiber Heartbeat Bypass Model Number
Port Speed	10 GIGABIT
Power Supply 1, 2	OFF or ON
Heartbeat Packet	<p>Default Heartbeat packet which can be loaded using the "reset defaults" command, or manually configured using the CLI.</p> <p>The CLI command is "set txpacket xx-xx-xx-xx-etc. The txpacket command must be a single line so it is a long long data type. If you remove all the carriage returns and comments (in parentheses) from the data below, you can use it to configure the heart beat packet from the CLI.</p> <p>The first 12 bytes are the source and destination addresses. They are followed by a sequence of bytes that define the packet type. The payload bytes are all 0's and the last four bytes are the packet checksum (CRC).</p> <pre> set txpacket 00-50-c2-3c-60-00- (source address) 00-50-c2-3c-60-01- (destination address) 81-37-ff-ff- (packet type) 00-30-00-00- 00-00-40-04- ec-a2-c6-13- 01-02-c6-13- 01-01-00-00- 00-00-00-00- (payload bytes) 00-00-00-00- 00-00-00-00- 00-00-00-00- 00-00-00-00- 00-00-00-00- a0-07-37-99 (CRC) </pre>
Bypass State	ON or OFF; see Chapter 1 for details.
Total Packets	Total number of packets that have passed through the iBypass unit since the last reset. When this value changes, a circled arrow appears next to the value to alert you to the change; if polling produces the same total packet result twice in a row, the circled arrow disappears.

Field	Description
Total Bytes	<p>Total number of bytes that have passed through the iBypass unit since the last reset. When this value changes, a circled arrow appears next to the value to alert you to the change; if polling produces the same byte total twice in a row, the circled arrow disappears.</p>
Oversized Packets	<p>This function tracks the number of oversized packets since the last reset. The Ethernet specification requires that no packet be larger than 1518 bytes (including checksum). Any packet that is larger than this is flagged as an error and discarded. These packets are also sometimes referred to as "Jabbers". Packets too big are almost always caused by faulty hardware. The network adapter card on a link showing a high rate of oversized packets should be replaced. Support IEEE 802.1q</p>
CRC Packets	<p>This function tracks the number of CRC errors since the last reset. MAC Frame CRC errors are the most common. Ethernet packets are encapsulated in a MAC frame that contains a preamble, and a post-envelope CRC check. The Ethernet adapter on the sending station creates the preamble, inserts the packet data (addressing, protocol, data, etc.), calculates a CRC checksum and inserts it at the end of the packet. If the receiving station determines that the checksum is incorrect, the packet is assumed to be bogus and is discarded.</p> <p>MAC frame CRC errors are typically caused by faulty cabling. If the cabling connecting an Ethernet Adapter or hub is faulty, the electric connection may be on and off many times during a transmission. This on-and-off state can interrupt parts of a transmission and damage the signal. If the signal is interrupted partially during transmission, the CRC checksum that was calculated by the network adapter is longer valid and the packet is flagged as a CRC error and discarded.</p> <p>CRC errors are common on a busy network, and a small percentage does not reflect a network problem. When the percentage is large, or when a single station shows a larger percent CRC errors, there is probably a problem.</p>

Modify an iBypass Switch Name or Address from System Manager

There are two ways to modify an iBypass Switch name or address. Either change them from the Configuration Tab for the device, or use the **Modify** option in the menu. The second method is described here..

To change a switch name or IP address from the Modify iBypass Switch dialog:

1. In the System Frame, select the image of the iBypass Switch you want to change.
2. Click **Modify** in the toolbar. The Modify iBypass Switch dialog appears.

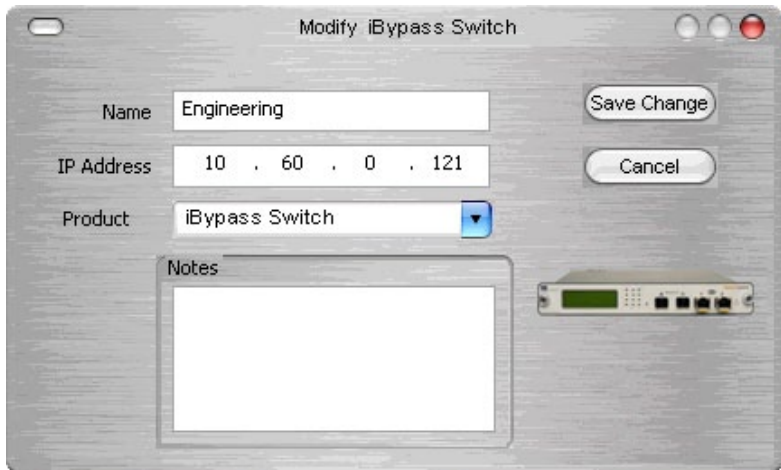

3. Change the name or IP address of the iBypass Switch.
4. Optionally add notes.
5. Click **Save Change**.

Change a Heartbeat Packet from System Manager

The heartbeat packet for a 10 GigaBit iBypass Switch can be configured. To change the default packet from the System Manager main menu, click **Transmit Heartbeat Packet** and change the values.

Uninstalling System Manager

If available, it is highly recommended that software be uninstalled through this option of Windows.

1. Click the Start menu button and navigate to Settings/Control Panel.
2. Double Click **Add/Remove Programs**.
3. Locate the Net Optics System Manager icon and click "Install/Uninstall" or "Change and Remove Programs buton."
4. Follow the instructions provided through the software wizard.
5. Upon completion some directories may need to be removed by hand.

Appendix A

Specifications and Models

Specifications

Electrical

Power Supply Input

100-240VAC, 0.5A, 47-63Hz

Power Supply Output

12V, 5A (10 GigaBit models), 3A (GigaBit models), 1.5A (10/100/1000 model)

Environmental

Operating Temperature

0°C to 40°C

Storage Temperature

-10°C to 70°C

Relative Humidity

10% min, 95% max, non-condensing

Mechanical

Dimensions

1.31" high x 12.4" deep x 8.75" (10 GigaBit models)

1.31" high x 11.0" deep x 8.75" (GigaBit and 10/100/1000 models)

IBPO-HBSR-XFP and IBPO-HBLR-XFP Connectors

- (1) DB9 RS232 serial console port
- (1) RJ45 management port
- (2) XFP, SFP or RJ45 monitoring ports (depending on model)
- (2) LC or RJ45 network ports (depending on model)

Indicators

- (1) 2x16 Character LCD
- (4) Link LEDs (Fiber Model)
- (4) Threshold Alarm LEDs (not included on 10/100/1000 model)
- (2) Power LEDs
- (2) Bypass Mode LEDs

Optical SR Fiber Type

Fiber Type: Corning Multimode 62.5/125µm or 50/125µm, wavelength 850nm

Split Ratio	Network Port Insertion Loss	Monitor Port Insertion Loss
60/40	1.25 dB	1.25 dB
50/50	1.25 dB	1.25 dB

Optical LR Fiber Type

Fiber Type: Corning Singlemode 8.5/125µm, wavelength 1310nm

Split Ratio	Network Port Insertion Loss	Monitor Port Insertion Loss
60/40	1.25 dB	1.25 dB
50/50	1.25 dB	1.25 dB

Transceiver Specifications

10 GigaBit SR 850nm, VCSEL

10 GigaBit LR 1310nm, Laser

GigaBit SX 850nm, VCSEL

GigaBit LX 1310nm, Laser

Software

iBypass Command Line Interface

Any terminal emulation software

Web Manager

Any browser

Net Optics System Manager

Windows 98, Windows 2000, Windows XP

SNMPv1 MIBs

NETOPTICS-BYPASS-MIB

NETOPTICSiDownload-MIB (used only to upgrade device software)

SNMP Traps

Bypass state changes

Utilization exceeds the threshold on any port

Any port link status changes

Port manually disabled

Either power supply state changes

Certifications

Fully RoHS compliant

Available Models

Models

Part Number	Description
IBPO-HBSR-XFP	10 GigaBit SR iBypass Switch with Heartbeat
IBPO-HBLR-XFP	10 GigaBit LR iBypass Switch with Heartbeat
IBPO-HB50SR-XFP	10 GigaBit SR iBypass Switch with Heartbeat, 50um
IBPO-HBER-XFP	10 GigaBit ER iBypass Switch with Heartbeat
IBPO-HBLX-SFP	GigaBit LX iBypass Switch with Heartbeat
IBPO-HBSX-SFP	GigaBit SX iBypass Swith with Heartbeat
IBP-HBCU3	10/100/1000 iBypass Switch with Heartbeat

Accessories

Part Number	Description
RK-iTP2	Two-slot rack-mount panel
XFPKT-SR	10 GigaBit Multimode Fiber XFP 62.5µm w/ cable
XFPKT-50SR	10 GigaBit Multimode Fiber XFP 50µm w/ cable
XFPKT-LR	10 GigaBit Singlemode Fiber XFP 1310nm w/ cable
XFPKT-ER	10 GigaBit Singlemode Fiber XFP 1550nm w/ cable
SFPKT-SX	GigaBit Multimode Fiber SFP 62.5µm w/ cable
SFPKT-50SX	GigaBit Multimode Fiber SFP 50µm w/ cable
SFPKT-LX	GigaBit Singlemode Fiber SFP 1310nm w/ cable
SFPKT-ZX	GigaBit Singlemode Fiber SFP 1550nm w/ cable
SFPKT-GCU	GigaBit Copper SFP w/ cable

Appendix B

Command Line Interface

iBypass Switch CLI Syntax

This Appendix contains information about the syntax to be used with each CLI command. The CLI is not case sensitive; commands may be entered with upper case or lower case letters.

Command	Sub-Command	Syntax	Description
Display		display <on off>	on = display port statistics on LCD off = display hw versions on LCD
Echo	n/a	echo <on off>	Stops typed character from being displayed on the screen
Help	Display	help display	Displays the display command options
	Echo	help echo	Displays the echo command options
	Ping	help ping	Displays the ping command options
	Reset	help reset	Displays the reset command options
	Set	help set	Displays the set command options
	Show	help show	Displays the show command options
	Web	help web	Displays the web command options
Ping	n/a	ping <d.d.d.d>	ping a network IP address
Reset	Peak	reset peak port <port ID>	Where <port ID> is A or B
	Statistics	reset statistics port <port ID>	Where <port ID> is A or B
	Default	reset default	Resets configuration to factory defaults
	Storage	reset storage	Deprecated; use reset default

Command	Sub-Command	Syntax	Description
Set	Community	set community <write read> <string>	set SNMP community string for writes and reads; string is 32 characters maximum
	Detection	set detection <on off>	Turns the Bypass Detection feature on or off
	Gateway	set gateway <d.d.d.d>	Where <d.d.d.d> is the ip address of the gateway
	HBpacket	set hbpacket <xx-xx-xx...>	Where <xx-xx-xx...> is the contents of the Heartbeat packet
	IP	set ip <d.d.d.d>	Where <d.d.d.d> is the ip address of the iTap
	LFD	set lfd <on off>	Turns the Link Fault Detect feature on or off
	Manager	set manager <d.d.d.d>	Where <d.d.d.d> is the ip address of the remote manager
	Mgtport	set mgtport <1 2>	1 = Enable management port 2 = Disable management port – makes SNMP and Web Manager unavailable
	Mode (software V2.2.1 and later)	set mode <1 2>	1 = Tap mode 2 = Bypass mode
	Netmask	set netmask <d.d.d.d>	Where <d.d.d.d> is the ip address netmask
	Parameter	set parameter port <parameter>	For fiber models, <parameter> is 64 = Disable monitor ports 96 = Enable monitor ports (other values not applicable) For 10/100/1000 model, see Page 49.
	Password	set password <password>	Where <password> is the authorized user's password, 9 characters or less
	Retry	set retry <1-255>	Number of missed Heartbeats to enter the BYPASS ON state
Threshold	set threshold port <port ID> <parameter>	Where <port ID> is A, B, 1, or 2 and <parameter> is 0 to 100 as % of port bandwidth	

Command	Sub-Command	Syntax	Description
Set (continued)	Time	set time <date & time>	Where <date & time> is mm/ dd/yyyy-hh:mm:ss
	Timeout	set timeout <0-255>	Heartbeat interval in msec (10G) or seconds (1G); 0 stops Heartbeats; in software earlier than V2.2.1, 0 forces BYPASS ON
	TXpacket	set txpacket <xx-xx-xx-...>	xx are bytes of the Heartbeat packet separated by (-), including a valid CRC
	Web-refresh	set web-refresh <20-900>	Web Manager page auto- refresh interval, in seconds
	Username	set username <username>	Where <username> is the authorized user's name, 9 characters or less
Show	Community	show community	Displays the SNMP read and write community strings
	Display	show display	Displays the display setting. Display OFF disables remote interfaces and front panel LCD
	Power	show power	Displays power status
	RXpacket	show rxpacket	Contents of received Heartbeat packet
	Set	show set	Displays currents settings
	Statistics	show statistics port <port ID>	Where <port ID> is A, B, 1, or 2
	Status	show status	Displays iTap status
	User	show user	Displays current user logged into the CLI
	Version	show version	Displays the software version
	Web	show web	Displays Web download settings and last error
Web (software update from a remote Web file server)	Download	web download	Start file download operation
	File	web file <filename>	File name for Web download
	Port	web port <number>	Port for Web download
	Remote- Download	web remote- download <on off>	Enable or disable download via Web Manager and SNMP
	URL	url <url_string>	URL for Web download

Note:

The default values for Timeout are 100 [milliseconds] on 10 GigaBit models and 1 [second] on other models. Default Retry is 3 packets. With these settings, the iBypass Switch goes to Bypass ON mode in 3x100 ms=300 ms (10 GigaBit models) if no Heartbeat packets are detected. If customer equipment latency exceeds 300 ms, then the iBypass Switch will go into Bypass ON mode before it detects the first Heartbeat packet. Customers should change one or both of the above default parameters to the higher number to avoid this behavior.

Set Parameter Port Command

The <parameter> values for the "set parameter port" command for the IBP-HBCU3 are defined in the following table. The selection applies to all four ports—the Network Ports and the Monitor Ports.

Note:

Enter <parameter> in decimal for the set parameter port command. The parameter is displayed in hex in response to the show set command.

Mode of all ports	Auto-negotiate	<parameter>	
		Hexadecimal	Decimal
10/100/1000Mbps, full duplex	On	0x37	55
10/100Mbps, full duplex	On	0x36	54
10Mbps	On	0x34	52
100Mbps	On	0x32	50
1000Mbps (Gigabit)	On	0x31	49
10Mbps, half duplex	Off	0x2C	44
100Mbps, half duplex	Off	0x2A	42
10Mbps, full duplex	Off	0x24	36
100Mbps, full duplex	Off	0x22	34
1000Mbps (Gigabit)	Off	0x21	33
Ports 1 and 2 disabled	Off	0x17	23

Limitations on Warranty and Liability

Net Optics offers a limited warranty for all its products. IN NO EVENT SHALL NET OPTICS, INC. BE LIABLE FOR ANY DAMAGES INCURRED BY THE USE OF THE PRODUCTS (INCLUDING BOTH HARDWARE AND SOFTWARE) DESCRIBED IN THIS MANUAL, OR BY ANY DEFECT OR INACCURACY IN THIS MANUAL ITSELF. THIS INCLUDES BUT IS NOT LIMITED TO LOST PROFITS, LOST SAVINGS, AND ANY INCIDENTAL OR CONSEQUENTIAL DAMAGES ARISING FROM THE USE OR INABILITY TO USE THIS PRODUCT, even if Net Optics has been advised of the possibility of such damages. Some states do not allow the exclusion or limitation of implied warranties or liability for incidental or consequential damages, so the above limitation or exclusion may not apply to you.

Net Optics, Inc. warrants this Tap to be in good working order for a period of ONE YEAR from the date of purchase from Net Optics or an authorized Net Optics reseller.

Should the unit fail anytime during the said ONE YEAR period, Net Optics will, at its discretion, repair or replace the product. This warranty is limited to defects in workmanship and materials and does not cover damage from accident, disaster, misuse, abuse or unauthorized modifications.

If you have a problem and require service, please call the number listed at the end of this section and speak with our technical service personnel. They may provide you with an RMA number, which must accompany any returned product. Return the product in its original shipping container (or equivalent) insured and with proof of purchase.

Additional Information

Net Optics, Inc. reserves the right to make changes in specifications and other information contained in this document without prior notice. Every effort has been made to ensure that the information in this document is accurate. Net Optics is not responsible for typographical errors.

THE WARRANTY AND REMEDIES SET FORTH ABOVE ARE EXCLUSIVE AND IN LIEU OF ALL OTHERS, EXPRESS OR IMPLIED. No Net Optics reseller, agent, or employee is authorized to make any modification, extension, or addition to this warranty.

Net Optics is always open to any comments or suggestions you may have about its products and/or this manual.

Send correspondence to
Net Optics, Inc.
5303 Betsy Ross Drive
Santa Clara, CA 95054 USA
Telephone: +1 (408) 737-7777
Fax: +1 (408) 745-7719
Email: info@netoptics.com / Internet: www.netoptics.com

All Rights Reserved. Printed in the U.S.A. No part of this publication may be reproduced, transmitted, transcribed, stored in a retrieval system, or translated into any language or computer language, in any form, by any means, without prior written consent of Net Optics, Inc., with the following exceptions: Any person is authorized to store documentation on a single computer for personal use only and that the documentation contains Net Optics' copyright notice.

www.netoptics.com