

User Guide

iTap 10 GigaBit Port Aggregator

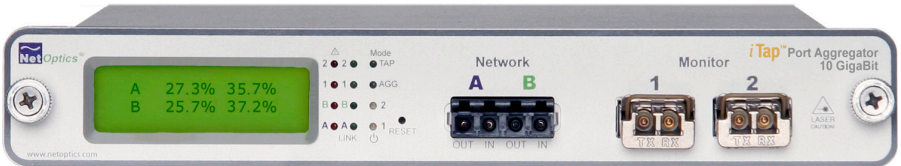

PLEASE READ THESE LEGAL NOTICES CAREFULLY.

By using a Net Optics iTap 10 GigaBit Port Aggregator you agree to the terms and conditions of usage set forth by Net Optics, Inc.

No licenses, express or implied, are granted with respect to any of the technology described in this manual. Net Optics retains all intellectual property rights associated with the technology described in this manual. This manual is intended to assist with installing Net Optics products into your network.

Trademarks and Copyrights

© 2010 by Net Optics, Inc. Net Optics® is a registered trademark of Net Optics, Inc. iTap™ is a trademark of Net Optics, Inc. Additional company and product names may be trademarks or registered trademarks of the individual companies and are respectfully acknowledged.

Additional Information

Net Optics, Inc. reserves the right to make changes in specifications and other information contained in this document without prior notice. Every effort has been made to ensure that the information in this document is accurate.

Contents

Chapter 1

Introduction	1
About this Guide	1
Features	1
Support	5

Chapter 2

Installing the iTap Port Aggregator	7
Plan the Installation	7
Unpack and Inspect the iTap Port Aggregator	8
Install XFP Monitor Port Modules	8
Rack Mount the iTap Port Aggregator (optional)	9
Connect Power to the iTap Port Aggregator	9
Connect the CLI Interface	10
Configure the iTap Port Aggregator using the CLI	12
Connect the iTap Port Aggregator to the Network	17
Connect the Management Port to the Network	18
Connect a Monitoring Device to the Port Aggregator	20
Check the Installation	21

Chapter 3

Front Panel	23
Display	24
Utilization Alarm LEDs	25
Link LEDs	25
Mode LEDs	25
Power LEDs	25
Reset Button	25

Chapter 4	
Using Web Manager	27
Access Web Manager	27
View System Status	29
View iTap Traffic Statistics	30
Change iTap Port Aggregator System Configuration	31
Chapter 5	
Using System Manager.	35
Install System Manager.	36
Explore System Manager	37
Create a System Manager Group	39
Delete a System Manager Group	40
Add Devices to a System Manager Group	40
Modify an iTap device Name or IP Address	42
Delete an iTap device from System Manager	43
View iTap Port Aggregator Information	43
Configure an iTap Port Aggregator	45
Appendix A	
Specifications and Models	49
Appendix B	
Command Line Interface	53
Limitations on Warranty and Liability	57

Chapter 1

Introduction

Thank you for purchasing the latest innovation in Tap technology, the iTap 10 GigaBit Port Aggregator (iTap Port Aggregator). This device provides ultra-efficient access to critical 10 Gigabit full-duplex links using only one NIC on each monitoring tool, and supports two tools simultaneously. In addition, the iTap feature gives you a quick visual reference of link performance: Bandwidth utilization is monitored and displayed on the front panel and through remote interfaces so you can see exactly what is happening on both sides of the network link. The iTap Port Aggregator also features a Tap mode, timestamping, and packet slicing.

About this Guide

This guide describes the installation and use of the following models:

Part Number	Description
IPA-SR5-XFP	10 Gig SR Multimode, 62.5µm, In-Line
IPA-50SR5-XFP	10 Gig SR Multimode, 50µm, In-Line
IPA-LR5-XFP	10 Gig LR Singlemode, 8.5µm, In-Line
IPA-ER5-XFP	10 Gig ER Singlemode, 8.5µm, In-Line

Features

Front Panel Display

The front panel display and alarm LEDs provide a quick visual check that link utilization levels are not exceeding the capacity of the monitoring device or a pre-determined threshold. From the display, you can view the current bandwidth utilization of each side of a full-duplex link, and the monitor ports, along with the size and time of the peak utilization for each port. After taking action on a utilization or peak event, you can reset the data from a recessed reset button on the front panel or remotely. With iTap technology, you have the information and the access points you need to respond quickly to network events.

Performance Aggregation

The iTap Port Aggregator combines and regenerates both directions of a full-duplex stream, sending all aggregated traffic to two separate monitoring ports. Typically, full-duplex monitoring with a network tap requires two network interface cards (NICs) (or a dual channel NIC), one interface for each side of the full-duplex link. Net Optics' iTap Port Aggregator enables one or two devices to simultaneously monitor a full-duplex link using only one NIC per device.

After the traffic has been aggregated to a single flow, it is difficult for the monitoring tool to distinguish the utilization levels of each side of the bi-directional link. The iTap Port Aggregator tracks the utilization levels before aggregation, keeping this vital information easily accessible from its remote and command line interfaces.

Remote Access

The iTap Port Aggregator is accessible from remote interfaces that provide information and control from anywhere in the network. Web Manager and System Manager software communicate over the remote interfaces to enable you to remotely set parameters, view status information, and monitor traffic statistical data. These tools provide security and performance information including the number of packets and bytes transferred, and the CRC error count. You can remotely set the alarm thresholds, clear the traffic data counters, and turn on or off a Monitor Port using a Web browser and the IP address of the Aggregator. The remote interfaces operate through a dedicated Management Port that can be connected to the network or isolated on a dedicated management VLAN for increased security.

Security, Visibility, and Reliability

A monitoring device connected to the iTap Port Aggregator sees all full-duplex traffic including Layer 1 and Layer 2 errors. Redundant power connections provide uptime protection. You have the option of configuring the iTap Port Aggregator so that it will not show data on the display. You can also turn off the Management Port, thereby preventing the device from being accessed over the network. In addition, Monitor Ports can be turned off to prevent unauthorized access to the network link.

Tap Mode

The iTap Port Aggregator can operate as a Port Aggregator (AGG mode) or as a conventional network Tap (TAP mode). In Tap mode, the device bridges all traffic between Network Ports A and B, while copying traffic from Network Port A to Monitor Port 1, and Network Port B to Monitor Port 2.

User-defined Maximum Packet Size

The user can set a maximum packet size of 64 to 12,000 bytes for each network port. If any oversized packets are received (the packet length exceeds the programmed value), they are counted and discarded. This function enables the iTap Port Aggregator to pass jumbo packets, but discard packets that are oversized as defined by the user.

Timestamping

When the timestamping feature is enabled, the iTap Port Aggregator replaces each packet's CRC with a timestamp before it is sent to the monitoring tool. The timestamp records the exact time that the packet arrived, and which Network Port it arrived from, so events can be correlated with other data.

The timestamp is a 32-bit value. A 30-bit timer is contained in the lower part of the timestamp. The timer increments every 6.4 nanoseconds (156 Mhz). The two most significant bits indicate the Network Port: 00 means Port A and 10 means Port B.

Optionally, a new CRC can be regenerated and appended to the packet so the monitoring tool does not see CRC errors due to the changed field. (See following section, CRC Regeneration.)

Packet Slicing

Sometimes it is desirable for monitoring tools to see only packet headers and not the packet payload. For example, when executing a lawful intercept, it may be illegal for the monitoring tool to read the packet payload. Another reason for passing only the packet headers is to reduce the bandwidth requirement on the monitor ports.

The iTap Port Aggregator supports this requirement by providing a packet slicing function. When packet slicing is enabled, a user-configurable number of bytes at the beginning of each packet are copied to the monitor ports, and the rest of the packet is discarded. (Of course, the full packets are always passed between Network Ports A and B.) Optionally, a new CRC can be regenerated and appended to the packet so the monitoring tool does not see CRC errors due to the truncated packets. (See **CRC Regeneration** on the following page.)

CRC Sanitizing

The iTap Port Aggregator can be set to drop packets from the monitoring data stream if they are received with CRC errors. This function can clean up the data being sent to monitoring tools, or it can be left off so the monitoring tool can see the packets that have CRC errors. In either case, packets received with CRC errors are counted and reported in the Port Statistics. All packets are always passed between Network Ports A and B regardless of CRC errors; this option only affects the traffic sent out the Monitor Ports. CRC Sanitizing is activated by setting Drop Bad Packet to ON.

CRC Regeneration

The iTap Port Aggregator can regenerate good CRC check bytes for packets as it copies them to the Monitor Ports. The four bytes of regenerated CRC are appended to the packet. For example, if packet slicing is set to 64 bytes, the resulting packet with CRC Regeneration is 68 bytes at the Monitor Port.

Timestamping and packet slicing inherently create packets with bad CRCs, so use CRC Regeneration if you don't want the monitoring tool to receive timestamped or sliced packets with CRC errors.

However, note that CRC Regeneration also converts packets with CRC errors to good packets before copying them to the monitoring tool. This situation should be avoided because the monitoring tool won't know the packets were received with CRC errors. Therefore, whenever CRC Regeneration is ON, it is advisable to turn on CRC Sanitizing as well, to prevent packets received with CRC errors from going to the Monitor Ports at all.

SNMP Traps

The iTap Port Aggregator transmits SNMP traps for the following events:

- Utilization exceeds the threshold on any port
- Any port link status changes
- Either power supply state changes

Ease of Use

- Display alternately shows link utilization, the peak utilization, and the time the peak utilization occurred, for all four ports
- LED indicators show redundant power, link status, Tap or Aggregation mode, and utilization alarms
- XFP monitor ports provide increased flexibility
- All necessary network and monitor cables are included
- Optional 19-inch rack frame holds up to two iTap Port Aggregators
- Compatible with all major manufacturers' monitoring devices, including protocol analyzers, probes, and intrusion detection/prevention systems
- Fully RoHS Compliant

Support

Net Optics offers technical support throughout the lifetime of your purchase. Our technical support team is available from 8 a.m. to 5 p.m. Pacific Time, Monday through Friday, at +1 (408) 737-7777 and via e-mail at ts-support@netoptics.com. FAQs are also available on Net Optics web site at www.netoptics.com.

Chapter 2

Installing the iTap Port Aggregator

This chapter describes how to install the iTap 10 GigaBit Port Aggregator.

The procedure follows these basic steps:

- Plan the installation
- Unpack and inspect the iTap Port Aggregator
- Install the XFP modules for the monitor ports
- Rack mount the iTap Port Aggregator (optional)
- Connect power to the iTap Port Aggregator
- Connect the command line interface (CLI) RS232 DB9 port
- Configure the iTap Port Aggregator parameters using the CLI
- Connect to network devices
- Connect the Management Port to the network
- Connect to monitoring devices
- Check the installation

After the iTap is installed, you can remotely monitor and control the iTap from Web Manager or System Manager.

Plan the Installation

Before you begin the installation of your iTap, determine the following:

- IP address of the iTap Port Aggregator or, for multiple iTaps, a range of IP addresses; Web Manager and System Manager connect at this address
- Net Mask for the iTaps
- IP address of the remote management console, if deployed over a WAN; this address is used for SNMP traps
- Gateway to the remote management console, if deployed over a WAN

Also make sure you have a suitable location to install the iTap. For fault-tolerant power redundancy, use two independent power sources.

Unpack and Inspect the iTap Port Aggregator

Unpack the iTap Port Aggregator and check for damaged or missing parts. The iTap ships with the following:

- iTap 10 GigaBit Port Aggregator
- Two power supplies with cords
- iTap 10 GigaBit Port Aggregator Quick Install Guide (one sheet)
- iTap Software CD
- iTap 10 GigaBit Port Aggregator User Guide (this document, on the iTap Software CD)
- Network and monitor cables
- RS232 DB9 cable for use with the CLI
- Extended Warranty if purchased

You may have also ordered rack unit panel for rack mounting the iTap. Carefully check the packing slip against parts received. If any part is missing or damaged, contact Net Optics' Customer Service immediately at +1 (408) 737-7777. (Note: XFP modules are ordered and shipped separately.)

Install XFP Monitor Port Modules

XFP modules are shipped separately. Remove the temporary plugs from the iTap Port Aggregator monitor slots and insert the XFP modules as shown below, until they click into place. The photograph on the cover of this Guide shows properly installed XFPs.

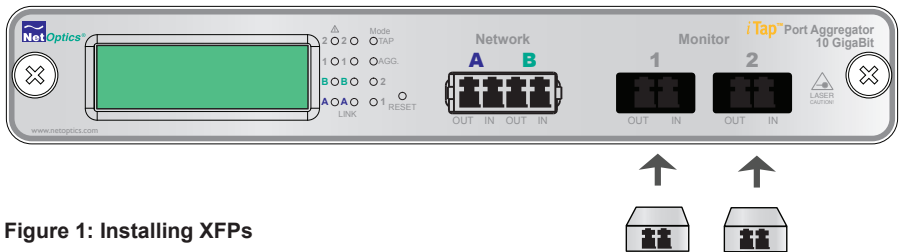

Figure 1: Installing XFPs

Rack Mount the iTap Port Aggregator (optional)

The iTap is designed for rack mounting in a two-slot, 19-inch panel. The mounting panel occupies one rack unit (1U).

To rack mount the iTap Port Aggregator:

1. Attach the two-slot panel to your rack using the attached thumbscrews.
2. Slide the iTap into one of the slots and secure with the attached thumbscrews.
3. Make sure that the rack is properly grounded.

The iTap can also be placed on a surface using the supplied pads.

Connect Power to the iTap Port Aggregator

Connect the power supplies on the back of the unit. If you are using redundant power, make sure that you connect the power supplies to two separate, independent power sources. One or both of the Power LEDs on the front panel should illuminate, depending on whether you used one power supply or two.

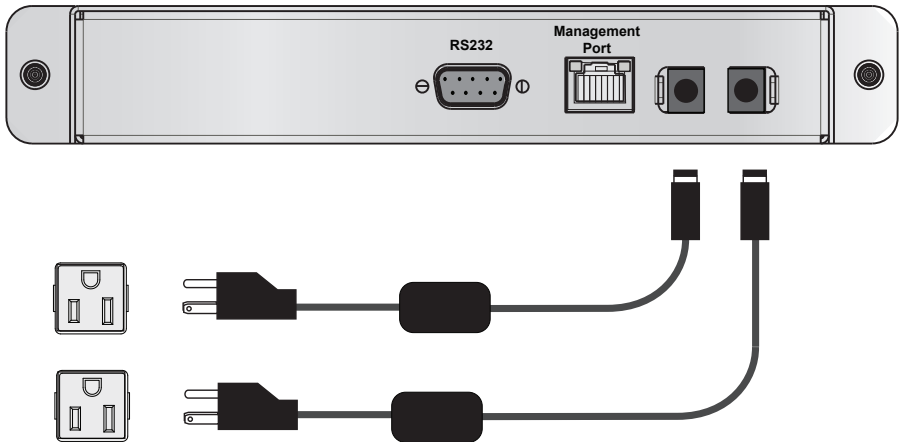

Figure 2: Connecting Power

Connect the CLI Interface

All configuration options, status, and statistics can be accessed using the device's Command Line Interface (CLI). To use the CLI, connect a DB9 cable from the RS232 port on the back of the iTap to your computer.

Your computer needs to have terminal emulation software such as HyperTerminal to access the iTap CLI over the RS232 cable.

To connect the CLI:

1. Connect a PC with terminal emulation software, such as HyperTerminal, to the iTap using the RS232 DB9 cable supplied with the iTap.

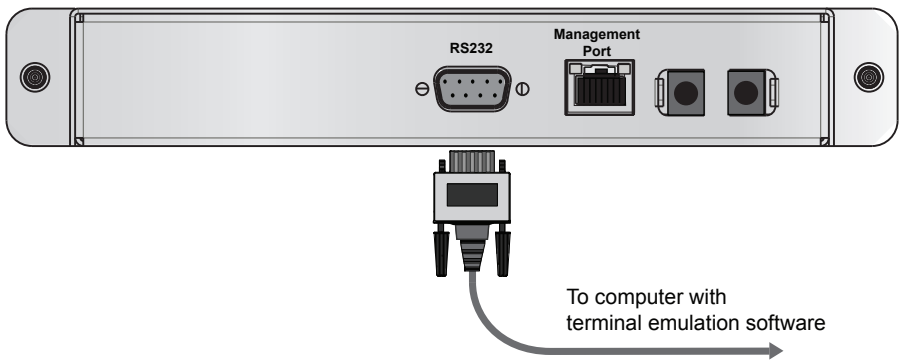

Figure 3: Connecting RS232 Cable to iTap

2. Launch terminal emulation software and set communication parameters to:

19200 baud
8 data bits
No parity
1 stop bit
No flow control

3. The Net Optics CLI banner and login prompt appear in the Terminal Emulation software (see following figure). Enter the username at the login prompt. The default username is **netoptics**.

```
*****  
* Net Optics Command Line Interface *  
*****  
login: netoptics  
password:
```

Figure 4: CLI login prompt

4. Enter the password. The default password is **netoptics**. The "NetOptics:" prompt is displayed.

```
*****  
* Net Optics Command Line Interface *  
*****  
login: netoptics  
password: netoptics  
Password Accepted  
NetOptics:
```

Figure 5: CLI default password and the "NetOptics:" prompt

Configure the iTap Port Aggregator using the CLI

You should be logged into the iTap Port Aggregator CLI. The factory-set default values for this iTap Port Aggregator are:

Username: **netoptics**

Password: **netoptics**

IP Address: **192.168.1.2**

Netmask: **255.0.0.0**

Display: **ON**

Management Port: **ON**

RX Threshold A: **50%**

RX Threshold B: **50%**

TX Threshold 1: **50%**

TX Threshold 2: **50%**

Port 1 Mode: **AGG**

Port 2 Mode: **AGG**

Port 1 Enable: **ON**

Port 2 Enable: **ON**

Port 1 CRC Regen: **OFF**

Port 2 CRC Regen: **OFF**

Port A Max Packet Size: **1518**

Port B Max Packet Size: **1518**

Port A TimeStamps: **OFF**

Port B TimeStamps: **OFF**

Port A Drop Bad Packet: **OFF**

Port B Drop Bad Packet: **OFF**

Port A Packet Slice: **OFF**

Port B Packet Slice: **OFF**

Port A Slice Size: **64**

Port B Slice Size: **64**

For security reasons, some parameters can only be set with the CLI. A complete list of CLI commands can be viewed by typing Help at the CLI prompt. It is also provided in Appendix B. You will now use the CLI to:

- Change the login username and password
- Assign a new IP address
- Change utilization thresholds
- Set the date and time
- View the device settings
- Try out the CLI Help command
- Turn the Management Port off and on
- Turn the front panel display off and on

Your terminal emulator should be displaying the "NetOptics:" prompt as shown here:

NetOptics:

If you do not see the "NetOptics:" prompt, try typing Help followed by the Enter key. If the prompt is still not displayed, repeat the instructions in the previous section **Connect the CLI Interface**.

While the CLI can be used to change all of the device setting, you also can change most of them later using the Web Manager or System Manager remote interfaces. (See Chapters 4 and 5).

Change the iTap Port Aggregator Username and Password

To change the username and password:

1. Change the username by entering the following command:
set username <new username>
2. Change the password by entering the following command:
set password <new password>
3. Record the username and password in a secure location.

Assign a New iTap Port Aggregator IP Address

Be sure that you have the correct new IP address for the iTap Port Aggregator before you change the IP address value from the default 192.168.1.2.

To assign a new IP address to the iTap Port Aggregator:

1. Type **set ip** *<new ip address>*.
2. Press **Enter**.

Example: Enter **set ip 192.168.1.3** to set the iTap Port Aggregator IP address to 192.168.1.3. Web Manager and System Manager can access the device at this address. Use **set manager** *<new ip address>* to set the address for SNMP traps.

Change Port Utilization Threshold Levels

To change the port utilization threshold levels:

1. Enter **set threshold port a** *<new level>* to set a percentage of available bandwidth for Port A. Utilization exceeding this limit will trigger an alarm.

Example: Enter **set threshold port a 30** to set the alarm threshold level for traffic received on Port A to 30%.

2. Repeat Step 1 for ports B, 1, and 2.

Set the Current Date and Time

To change the current date and time:

- Enter **set time** *<mm/dd/yyyy-hh:mm:ss>* where *mm* is month, *dd* is day of the month, *yyyy* is year, *hh* is hour, *mm* is minutes, and *ss* is seconds.

Time is based on the 24-hour clock. This clock is used to record the time of traffic peak utilization events.

View Current Settings

To view the current settings:

- Enter **show set 1** and **show set 2**. The CLI displays the current settings; it will be similar to the example shown on the following page.

```

NetOptics: show set 1

    Model:                10G 62.5um SR Inline
    System Time:          05/08/2008 11:29:42
    IP Address:           192.168.1.2
    Netmask:              255.0.0.0
    Manager:              192.168.0.1
    Gateway:              10.0.0.1
    Port 1 Enable:        ON
    Port 2 Enable:        ON
    Display:              ON
    Management Port:      ON

    RX Threshold A:      50
    RX Threshold B:      50
    TX Threshold 1:       50
    TX Threshold 2:       50

NetOptics: show set 2

    Port 1 Mode:          AGG
    Port 2 Mode:          AGG
    Port 1 CRC Regen:     OFF
    Port 2 CRC Regen:     OFF

    Port A Max Packet Size: 1518
    Port B Max Packet Size: 1518
    Port A TimeStamps:    OFF
    Port B TimeStamps:    OFF
    Port A Drop Bad Packet: OFF
    Port B Drop Bad Packet: OFF

    Port A Packet Slice:  OFF
    Port B Packet Slice:  OFF
    Port A Slice Size:     64
    Port B Slice Size:     64
    
```

Figure 6: Show Set command example

Tip!

*Simply entering **show set** will display all of the settings at once; however, some of the settings may scroll off your screen because the list is long.*

Using the CLI Help Command

To view CLI help information:

1. Enter **Help** at the "NetOptics:" prompt. The list of help topics is displayed.

```

NetOptics: help

*****
* Net Optics Command Line Interface *
*****

Usage: "help <variable>"

<variable>:
set      - Configure various options.
reset    - Reset options.
show     - Show current configurations and status.
echo     - Turn on or off echoing of characters.
help    - This help screen.

NetOptics:
    
```

Figure 7: iTap Port Aggregator CLI Help Menu

2. To view the syntax for changing the iTap Port Aggregator configuration parameters, enter **help set**.
3. Repeat with the command of interest to view the syntax for all commands available from the CLI. You can also enter a command and one of its parameters.

Example: Enter **help set threshold** to see the usage of that command.

For a complete listing of CLI commands, see Appendix B.

Do not disconnect the DB9 cable from the RS232 port yet. You will use it again to turn the iTap Port Aggregator front panel display on and off.

Connect the iTap Port Aggregator to the Network

To connect the iTap to the network:

1. Connect Network Port A to the appropriate network device using the cables supplied with your iTap.

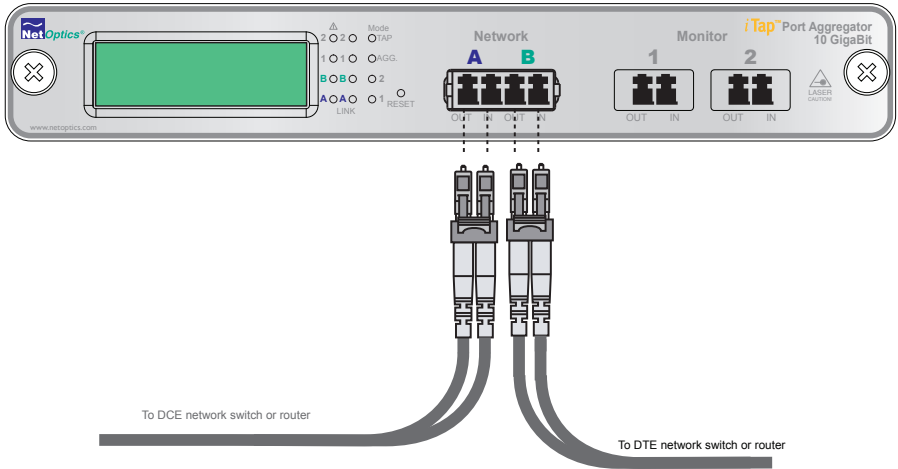

Figure 8: Connecting Ports A and B to the Network

2. Connect Network Port B to the appropriate network device using the cables supplied with your iTap.
3. Verify that the iTap Network Ports are cabled in-line between two devices.

Connect the Management Port to the Network

To use the remote interfaces you must connect the Management Port on the back of the unit to the network. You may wish to connect the Management Port on a dedicated management VLAN for increased security.

To connect the Management Port:

1. Connect a CAT5 or CAT5e cable to the Management Port as shown in the following figure.

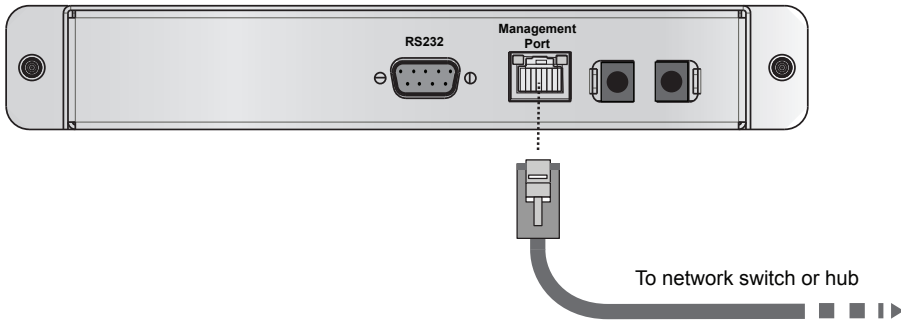

Figure 9: Connecting the Management Port

2. Connect the other end of the cable to a network switch or hub.

Turn the Management Port Off and On

Check that the Management Port is functional by typing the iTap Port Aggregator IP address in a Web browser. Net Optics Web Manager should display. If it does not, check the Management Port cable connections and use the following procedure to make sure the Management Port is ON.

To turn the Management Port off and on:

1. Enter **show set 1** to view the current setting. Management Port should be ON. Use Web Manager to verify that the Management Port is operational.
2. Enter **set mgtport 2**. The Management Port turns off.
3. Enter **show set 1** to view the current setting. Management Port should be OFF. Use Web Manager to verify that the Management Port is off; the browser cannot refresh Web Manager because it cannot communicate with the iTap.
4. Enter **set mgtport 1**. The Management Port turns on.
5. Enter **show set 1** to view the current setting. Management Port should be ON. Use Web Manager to verify that the Management Port is operational.

Turn the Front Panel Display Off and On

To turn the front panel display off and on:

1. Enter **show set 1** to view the current setting. Display should be ON. Look at the display to verify that it is on; port utilization statistics should be visible.
2. Enter **set display 2**. The display turns off.
3. Enter **show set 1** to view the current setting. Display should be OFF. Look at the display to verify that port utilization statistics are not visible. The display shows "Net Optics, Inc." and the firmware compile date in OFF mode.
4. Enter **set display 1**. The display turns on.
5. Enter **show set 1** to view the current setting. Display should be ON. Look at the display to verify that port utilization statistics are again visible.

Connect a Monitoring Device to the Port Aggregator

The iTap Port Aggregator is delivered with two monitor cables for connecting to monitoring tools.

To connect the cables to the monitoring devices:

1. Connect Monitor Port 1 to the appropriate monitoring device using the cables supplied with your unit
2. Connect Monitor Port 2 to the appropriate monitoring device using the cables supplied with your unit

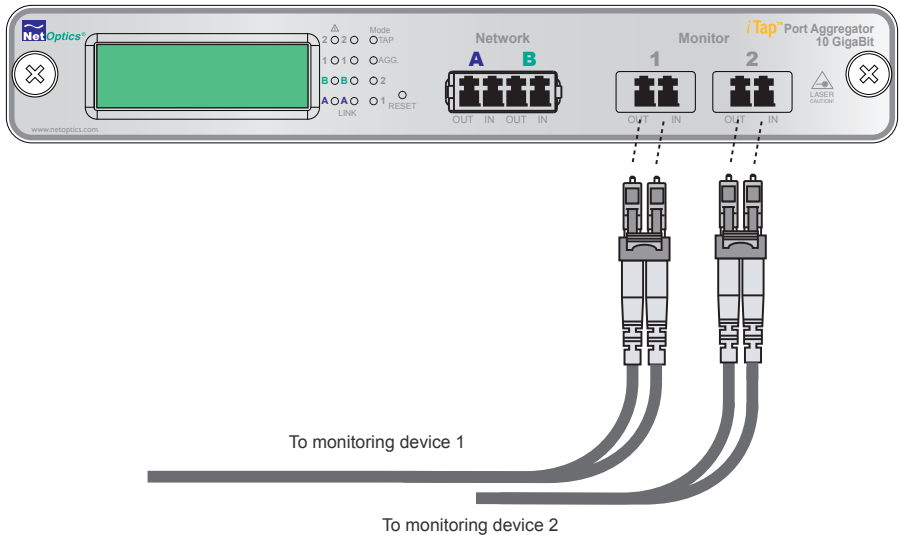

Figure 10: Connecting Two Monitoring Devices

Check the Installation

You have connected the iTap Port Aggregator to the network, to the monitoring device, and to power. It should now be functioning correctly. Check the status of the following:

- Check that at least one power LED is illuminated.
- Check the link status LEDs located on the front panel to verify that the links are connected.
- Check the display for utilization and peak information.
- Verify that the monitoring devices are receiving traffic from the iTap Port Aggregator.
- Verify that the Management Port is functional by typing the iTap Port Aggregator's IP address in a Web browser. Net Optics' Web Manager should appear.

Chapter 3 Front Panel

This chapter describes how to interpret and work with the front panel features of the iTap Port Aggregator. The following topics are covered:

- Display
- LED indicators
- Reset Button

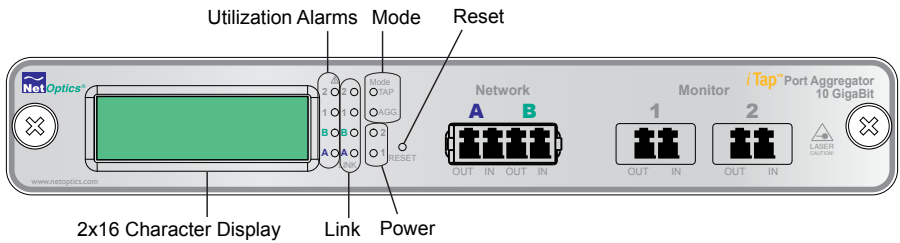

Figure 11: iTap Port Aggregator Front Panel

The iTap front panel provides information in two ways. The display shows utilization and peak information and the LEDs show device mode, link status, and alarm conditions. The front panel also has a recessed reset button to clear the peak data.

Display

The front panel of the iTap provides port traffic information on a 2x16 character LCD display. After a boot up message, the display scrolls through the following four screens.

- Two screens show the Network and Monitor Port current and peak utilizations, and are displayed for 10 seconds each.
- The other two screens show the times of the peak utilizations, and are displayed for 5 seconds each.
- On each screen, the top line shows one port and the bottom line shows another.

Display Message	Time	Description
A XX.X% PP.P% B XX.X% PP.P%	10 sec	Percent of Network Port bandwidth being used by incoming traffic Line 1 is Port A; line 2 is Port B XX.X% = Current utilization PP.P% = Peak utilization
1 XX.X% PP.P% 2 XX.X% PP.P%	10 sec	Percent of Monitor Port bandwidth being used by outgoing traffic Line 1 is Port 1; line 2 is Port 2 XX.X% = Current utilization PP.P% = Peak utilization
A@ hh:mm:ss B@ hh:mm:ss	5 sec	Times of Network Port peak utilizations Line 1 is Port A; line 2 is Port B hh:mm:ss = Time in hours : minutes : seconds
1@ hh:mm:ss 2@ hh:mm:ss	5 sec	Times of Monitor Port peak utilizations Line 1 is Port 1; line 2 is Port 2 hh:mm:ss = Time in hours : minutes : seconds

Example: If several peaks occur, the iTap Port Aggregator provides information (peak utilization and time of peak utilization) on the highest peak event. While the front panel display shows only the time of the peak events, Web Manager and System Manager provide dates as well.

If data is not displaying as expected, check the Network Port connectors for link status and activity. Also check the status of the Display using the CLI. When the display is in the OFF state, it shows "Net Optics, Inc." and the firmware compile date.

Utilization Alarm LEDs

Four LEDs indicate that utilization levels have exceeded the threshold. Each LED is the alarm for one port. For Network Ports, utilization is monitored on incoming traffic; for Monitor Ports, the outgoing traffic is monitored. When a Utilization Alarm LED is illuminated, it indicates that the threshold level was exceeded for that port since the last reset. The LEDs remain illuminated until they are reset using the reset button or remote interfaces.

Link LEDs

Four LEDs indicate link status. If a good link is established on a port, the LED corresponding to that port illuminates. The Link LED blinks when traffic is passing through the port; the intensity of the blinking increases with the utilization; it becomes noticeable for utilizations of about 30 percent or greater.

Mode LEDs

If the device is in Tap mode, the TAP LED illuminates. If the device is in Aggregation mode, the AGG LED illuminates. (If both mode LEDs are illuminated or both are off, check that the Mode bits are set to the same value for both Monitor Ports.)

Power LEDs

If the iTap Port Aggregator is deployed with both power supplies, both power LEDs illuminate when connected to power. If a power LED is off, the corresponding power supply is disconnected or not functioning.

Reset Button

Press the Reset button to reset the traffic peaks and times on the display, and the Utilization Alarm LEDs. To prevent accidental resets, the Reset button is recessed into the front panel. To push the Reset button, use a thin, rigid tool such as a paperclip.

The traffic peak and time can also be reset using the CLI or remote interfaces.

Chapter 4

Using Web Manager

This chapter describes how to monitor and control individual iTap Port Aggregators using Net Optics Web Manager software.

The iTap Port Aggregator has built-in support for remote control from any computer with an Internet browser and access to the iTap's IP address. Web Manager is a browser-based interface that enables you to change settings, view status, and retrieve data remotely. Web Manager supports all common browsers.

In this chapter, you will learn to:

- Access Web Manager
- View iTap Port Aggregator System Status from Web Manager
- View iTap Traffic Statistics from Web Manager
- Change the iTap Port Aggregator System Configuration from Web Manager

Note:

*To access Web Manager, the Web browser must have a path to the iTap Port Aggregator Management Port. In addition, the Management Port option in the CLI must be set to ON. For more information, see **Configure the iTap Port Aggregator Using the CLI**.*

Access Web Manager

To access Web Manager:

1. Open an Internet browser on your computer.
2. Enter the iTap's IP address in the URL box and press Enter. The default IP address is 192.168.1.2. The Web Manager page appears. (See the figure on the following page.)

iTap 10Gigabit Dual Port Aggregator

System Status

System Status	<input type="text" value="UP"/>	System Model	<input type="text" value="10G 62.5um SR Inline"/>
Port A Link Status	<input type="text" value="UP"/>	Port B Link Status	<input type="text" value="UP"/>
Port 1 Link Status	<input type="text" value="UP"/>	Port 2 Link Status	<input type="text" value="DOWN"/>
Power Supply 1 Status	<input type="text" value="OFF"/>	Power Supply 2 Status	<input type="text" value="ON"/>

Port A Statistics

Port A Peak Rate (%)	<input type="text" value="97"/>	Port B Peak Rate (%)	<input type="text" value="98"/>
Port A Peak Date & Time	<input type="text" value="10/24/2022 08:45:38"/>	Port B Peak Date & Time	<input type="text" value="10/24/2022 12:24:57"/>
Port A Current Utilization Rate (%)	<input type="text" value="59"/>	Port B Current Utilization Rate (%)	<input type="text" value="62"/>
Port A Total Packets	<input type="text" value="2875923861"/>	Port B Total Packets	<input type="text" value="4220436150"/>
Port A Total Bytes	<input type="text" value="303173037"/>	Port B Total Bytes	<input type="text" value="303173037"/>
Port A CRC Errors	<input type="text" value="0"/>	Port B CRC Errors	<input type="text" value="0"/>
Port A Oversize Packets	<input type="text" value="4033814575"/>	Port B Oversize Packets	<input type="text" value="0"/>

Port 1 Statistics

Port 1 Peak Rate (%)	<input type="text" value="100"/>	Port 2 Peak Rate (%)	<input type="text" value="100"/>
Port 1 Peak Date & Time	<input type="text" value="10/24/2022 08:45:38"/>	Port 2 Peak Date & Time	<input type="text" value="10/24/2022 12:24:57"/>
Port 1 Current Utilization Rate (%)	<input type="text" value="76"/>	Port 2 Current Utilization Rate (%)	<input type="text" value="76"/>
Port 1 Total Packets	<input type="text" value="3240952268"/>	Port 2 Total Packets	<input type="text" value="3238948643"/>
Port 1 Total Bytes	<input type="text" value="2374863140"/>	Port 2 Total Bytes	<input type="text" value="2374863140"/>

Port 2 Statistics

System Configuration

IP Address	<input type="text" value="192.168.1.2"/>	Manager IP Address	<input type="text" value="192.168.0.1"/>
Net Mask	<input type="text" value="255.0.0.0"/>	Gateway IP Address	<input type="text" value="10.0.0.1"/>
Port 1 Enable	<input type="text" value="ON"/>	Port 2 Enable	<input type="text" value="ON"/>
Port A Utilization Threshold (%)	<input type="text" value="50"/>	Port B Utilization Threshold (%)	<input type="text" value="50"/>
Port 1 Utilization Threshold (%)	<input type="text" value="50"/>	Port 2 Utilization Threshold (%)	<input type="text" value="50"/>
Reset Port A Peak Rate	<input type="text" value="No"/>	Reset Port B Peak Rate	<input type="text" value="No"/>
Reset Port 1 Peak Rate	<input type="text" value="No"/>	Reset Port 2 Peak Rate	<input type="text" value="No"/>
Reset Port A Statistics	<input type="text" value="No"/>	Reset Port B Statistics	<input type="text" value="No"/>
Reset Port 1 Statistics	<input type="text" value="No"/>	Reset Port 2 Statistics	<input type="text" value="No"/>
Port 1 Mode	<input type="text" value="AGG"/>	Port 2 Mode	<input type="text" value="AGG"/>
Port 1 Regenerate CRC	<input type="text" value="OFF"/>	Port 2 Regenerate CRC	<input type="text" value="OFF"/>
Port A Timestamp	<input type="text" value="OFF"/>	Port B Timestamp	<input type="text" value="OFF"/>
Port A Drop Bad Packet	<input type="text" value="OFF"/>	Port B Drop Bad Packet	<input type="text" value="OFF"/>
Port A Maximum Packet Size (Bytes)	<input type="text" value="1518"/>	Port B Maximum Packet Size (Bytes)	<input type="text" value="12000"/>
Port A Packet Slicing	<input type="text" value="OFF"/>	Port B Packet Slicing	<input type="text" value="OFF"/>
Port A Sliced Packet Size (Bytes)	<input type="text" value="64"/>	Port B Sliced Packet Size (Bytes)	<input type="text" value="64"/>

Figure 12: Web Manager for the iTap 10 GigaBit Port Aggregator

The tables in the following sections explain the fields in Web Manager. To save any changes to the iTap, click **Submit Changes** at the bottom of the page.

View System Status

Web Manager displays status information about the iTap Port Aggregator and its ports. System Status UP indicates the iTap is functioning correctly. If the System Status is DOWN, there is an internal error. For more information, contact Net Optics Technical Support.

In addition to the System Status, you can view the status of each iTap port and power supply as shown in the following figure.

iTap 10Gigabit Dual Port Aggregator

System Status

System Status	<input type="text" value="UP"/>	System Model	<input type="text" value="10G 62.5um SR Inline"/>
Port A Link Status	<input type="text" value="UP"/>	Port B Link Status	<input type="text" value="UP"/>
Port 1 Link Status	<input type="text" value="UP"/>	Port 2 Link Status	<input type="text" value="DOWN"/>
Power Supply 1 Status	<input type="text" value="OFF"/>	Power Supply 2 Status	<input type="text" value="ON"/>

Figure 13: iTap System, Link, and Power Status (top part of Web Manager page)

The following table describes the status fields.

Field Name	Value	Description
System Status	UP/DOWN	DOWN indicates an internal error; call Net Optics Customer Service for assistance
System Model	10G 62.5um SR Inline	Identifies the device model
Port A Link Status	UP/DOWN	Indicates the state of incoming traffic on Port A
Port B Link Status	UP/DOWN	Indicates the state of incoming traffic on Port B
Port 1 Link Status	UP/DOWN	Indicates the state of communication on Port 1
Port 2 Link Status	UP/DOWN	Indicates the state of communication on Port 2
Power Supply 1 Status	ON/OFF	Indicates whether the iTap Port Aggregator is receiving power from Power Supply 1
Power Supply 2 Status	ON/OFF	Indicates whether the iTap Port Aggregator is receiving power from Power Supply 2

If a link is down, check the cables and power supplies, and make sure the device on the other end of the link is functioning properly.

View iTap Traffic Statistics

Web Manager displays iTap traffic statistics for both Network Ports and both Monitor Ports. The statistics for the Network Ports apply to traffic received into the port. The statistics for the Monitor Ports apply to traffic transmitted out of the port.

Port A Statistics		Port B Statistics	
Port A Peak Rate (%)	97	Port B Peak Rate (%)	98
Port A Peak Date & Time	10/24/2022 08:45:38	Port B Peak Date & Time	10/24/2022 12:24:57
Port A Current Utilization Rate (%)	59	Port B Current Utilization Rate (%)	62
Port A Total Packets	2875923861	Port B Total Packets	4220436150
Port A Total Bytes	303173037	Port B Total Bytes	303173037
Port A CRC Errors	0	Port B CRC Errors	0
Port A Oversize Packets	4033814575	Port B Oversize Packets	0
Port 1 Statistics		Port 2 Statistics	
Port 1 Peak Rate (%)	100	Port 2 Peak Rate (%)	100
Port 1 Peak Date & Time	10/24/2022 08:45:38	Port 2 Peak Date & Time	10/24/2022 12:24:57
Port 1 Current Utilization Rate (%)	76	Port 2 Current Utilization Rate (%)	76
Port 1 Total Packets	3240952268	Port 2 Total Packets	3238948643
Port 1 Total Bytes	2374863140	Port 2 Total Bytes	2374863140

Figure 14: iTap Network and Monitor Port Statistics (middle part of Web Manager page)

The iTap Port Aggregator periodically sends updated statistics to Web Manager. The statistics can also be updated by refreshing your browser. All counters reflect counts since the last statistics reset; they are 32-bit counters that roll over from their maximum count (approximately 4.3 billion) to 0, which may happen frequently for the Total Bytes count. The following table defines the traffic statistics available from Web Manager.

Field Name	Description
Peak Rate (%)	Highest utilization since last reset
Peak Date & Time	When the peak occurred
Current Utilization Rate (%)	Utilization level of the port bandwidth
Total Packets	Total packets received
Total Bytes	Total bytes received
CRC Errors	Number of CRC errors
Oversize Packets	Number of oversize packets

Change iTap Port Aggregator System Configuration

Web Manager has both read-only and writable fields. Use the writable fields in the Aggregator System Configuration section to set configuration parameters. To change a parameter, type the new value into the field or select it from the list, and then click **Submit Changes** at the bottom of the page to send the changes to the iTap Port Aggregator device.

Note:

*If you receive a message saying that your browser needs to resend the information when you try to refresh your browser, return to the main Web Browser page by re-entering the iTap Port Aggregator IP address in the browser's address bar. Otherwise, you may not see current data when you refresh the browser. This condition occurs only if you are looking at the "index.shtml" page (for instance, <http://192.168.1.2/index.shtml>) that comes up after you **Submit Changes**.*

System Configuration

IP Address <input type="text" value="192.168.1.2"/>	Manager IP Address <input type="text" value="192.168.0.1"/>
Net Mask <input type="text" value="255.0.0.0"/>	Gateway IP Address <input type="text" value="10.0.0.1"/>
Port 1 Enable <input type="button" value="ON"/>	Port 2 Enable <input type="button" value="ON"/>
Port A Utilization Threshold (%) <input type="text" value="50"/>	Port B Utilization Threshold (%) <input type="text" value="50"/>
Port 1 Utilization Threshold (%) <input type="text" value="50"/>	Port 2 Utilization Threshold (%) <input type="text" value="50"/>
Reset Port A Peak Rate <input type="button" value="No"/>	Reset Port B Peak Rate <input type="button" value="No"/>
Reset Port 1 Peak Rate <input type="button" value="No"/>	Reset Port 2 Peak Rate <input type="button" value="No"/>
Reset Port A Statistics <input type="button" value="No"/>	Reset Port B Statistics <input type="button" value="No"/>
Reset Port 1 Statistics <input type="button" value="No"/>	Reset Port 2 Statistics <input type="button" value="No"/>
Port 1 Mode <input type="button" value="AGG"/>	Port 2 Mode <input type="button" value="AGG"/>
Port 1 Regenerate CRC <input type="button" value="OFF"/>	Port 2 Regenerate CRC <input type="button" value="OFF"/>
Port A Timestamp <input type="button" value="OFF"/>	Port B Timestamp <input type="button" value="OFF"/>
Port A Drop Bad Packet <input type="button" value="OFF"/>	Port B Drop Bad Packet <input type="button" value="OFF"/>
Port A Maximum Packet Size (Bytes) <input type="text" value="1518"/>	Port B Maximum Packet Size (Bytes) <input type="text" value="12000"/>
Port A Packet Slicing <input type="button" value="OFF"/>	Port B Packet Slicing <input type="button" value="OFF"/>
Port A Sliced Packet Size (Bytes) <input type="text" value="64"/>	Port B Sliced Packet Size (Bytes) <input type="text" value="64"/>

Figure 15: iTap Configuration (bottom part of Web Manager page)

The following table describes each available configuration option.

Field Name	Description
IP Address	IP address of the iTap. The default IP address is 192.168.1.2. Change the IP address by typing a new IP address in the text box. This is the address for Web Manager and System Manager to communicate with the device.
Net Mask	Displays current Net Mask of the iTap. The default Net Mask is 255.0.0.0. Change the IP address by typing a new Net Mask in the text box.
Manager IP Address	IP Address of the system management computer running over a WAN. SNMP traps go to this address. Change the IP address by typing a new IP address in the text box.
Gateway IP Address	Displays current IP Address of the current WAN Gateway. Change the Gateway by typing a new IP address in the text box.
Port 1 Enable	Select ON to enable the laser for Monitor Port 1.
Port 2 Enable	Select ON to enable the laser for Monitor Port 2.
Port A Utilization Threshold (%)	Enter the utilization level that will trigger a threshold alarm for Port A.
Port B Utilization Threshold (%)	Enter the utilization level that will trigger a threshold alarm for Port B.
Port 1 Utilization Threshold (%)	Enter the utilization level that will trigger a threshold alarm for Port 1.
Port 2 Utilization Threshold (%)	Enter the utilization level that will trigger a threshold alarm for Port 2.
Reset Port A Peak Rate	Select Yes to reset the Peak data for Port A.
Reset Port B Peak Rate	Select Yes to reset the Peak data for Port B.
Reset Port 1 Peak Rate	Select Yes to reset the Peak data for Port 1.
Reset Port 2 Peak Rate	Select Yes to reset the Peak data for Port 2.
Reset Port A Statistics	Select Yes to zero all counters for Port A.
Reset Port B Statistics	Select Yes to zero all counters for Port B.

Field Name	Description
Reset Port 1 Statistics	Select Yes to zero all counters for Port 1.
Reset Port 2 Statistics	Select Yes to zero all counters for Port 2.
Port 1 Mode	Select AGG to set Port 1 to aggregation mode. Select TAP to set Port 1 to Tap mode. <i>Note: Both Monitor Ports must always be set to the same mode or the device behavior will be undefined.</i>
Port 2 Mode	Select AGG to set Port 2 to aggregation mode. Select TAP to set Port 2 to Tap mode. <i>Note: Both Monitor Ports must always be set to the same mode or the device behavior will be undefined.</i>
Port 1 Regenerate CRC	Select ON to set Port 1 to append a regenerated CRC to each packet.
Port 2 Regenerate CRC	Select ON to set Port 2 to append a regenerated CRC to each packet.
Port A Timestamp	Select ON to set Port A to timestamp packets.
Port B Timestamp	Select ON to set Port B to timestamp packets.
Port A Drop Bad Packet	Select ON to set Port A to drop packets with CRC errors.
Port B Drop Bad Packet	Select ON to set Port B to drop packets with CRC errors.
Port A Maximum Packet Size (Bytes)	Enter a value from 64 and 12000 to change the value of the maximum packet size on Port A.
Port B Maximum Packet Size (Bytes)	Enter a value from 64 and 12000 to change the value of the maximum packet size on Port B.
Port A Packet Slicing	Select ON to set Port A to packet slice.
Port B Packet Slicing	Select ON to set Port B to packet slice.
Port A Sliced Packet Size (Bytes)	Enter a value from 64 and 12000 to change the number of bytes at which the packet received at Port A is sliced when Port A packet slicing is ON.
Port B Sliced Packet Size (Bytes)	Enter a value from 64 and 12000 to change the number of bytes at which the packet received at Port B is sliced when Port B packet slicing is ON.
Set Date and Time	Click this button the view or change the date and time of the iTap Port Aggregator clock. This clock is used to record the time of traffic utilization peaks.

Chapter 5

Using System Manager

This chapter describes how to install and use Net Optics' System Manager, a software tool that provides a central console to manage all the iTap-enabled Net Optics devices on your network. Using System Manager, you can change settings, view status, and retrieve data remotely from multiple Net Optics iTap devices.

System Manager is compatible with computers and workstations running Windows XP, Windows 2000, and Windows 98. Windows Vista is not supported at this time.

In this chapter, you will learn to:

- Install System Manager
- Explore System Manager
- Create a System Manager Group
- Delete a System Manager Group
- Add iTap devices to a System Manager Group
- Modify an iTap device Name or IP Address
- Delete an iTap device
- View iTap Port Aggregator Information
- Configure an iTap Port Aggregator

Install System Manager

The installation executable file for System Manager is on the CD included with the iTap device.

To install System Manger:

1. Load the System Manager software CD in the computer's CD drive. The License Agreement dialog box appears. (If the License Agreement dialog box does not appear, locate **Setup.exe** on the CD and double click it.)

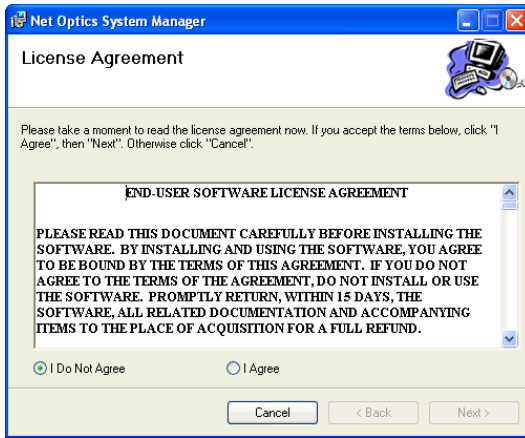

Figure 16: Net Optics System Manager License Agreement

2. After reading the License Agreement, select **I Agree** and click **Next** to install System Manager. The Setup Welcome screen appears.
3. Click **Next**. The Select Installation Folder dialog box appears.
4. To install in the default folder, make no changes to the path in the Folder: text box. To install in a different location, either type the path in the Folder: text box or click **Browse** to find another location. To check the space available for System Manager on the selected drive, click **Disk Cost**.
5. To limit access to System Manager to the current user of the PC, select **Just Me**. To enable access to any user logged into the PC, select **Everyone**.
6. Click **Next**. The Confirm Installation dialog box appears.

7. To continue the installation, click **Next**. The Progress dialog box appears. When the installation is complete, the Installation Complete dialog box appears.
8. Click **Close**.

System Manager is now installed on your computer and a Net Optics shortcut icon appears on your desktop.

Explore System Manager

This section describes the features and functions of System Manager. With System Manager you can:

- Create iTap device groups
- Add and delete iTap devices from the system
- Remotely configure iTap devices
- View traffic utilization and peaks
- View traffic statistics

NOTE:

*To access the iTap Port Aggregator with System Manager, the System Manager computer must have a path to the iTap Port Aggregator Management Port. In addition, the Management Port option in the CLI must be set to ON. For more information, see **Configure the iTap Port Aggregator Using the CLI**.*

To access System Manager:

1. Double click the System Manager icon on your PC desktop. The Net Optics System Manager login dialog box appears.
2. Enter the System Manager User Name and Password. Net Optics System Manager opens. The default User Name is **netoptics** and the default Password is **netoptics**.

Tip!

The System Manager User Name and Password may be different than the CLI username and password.

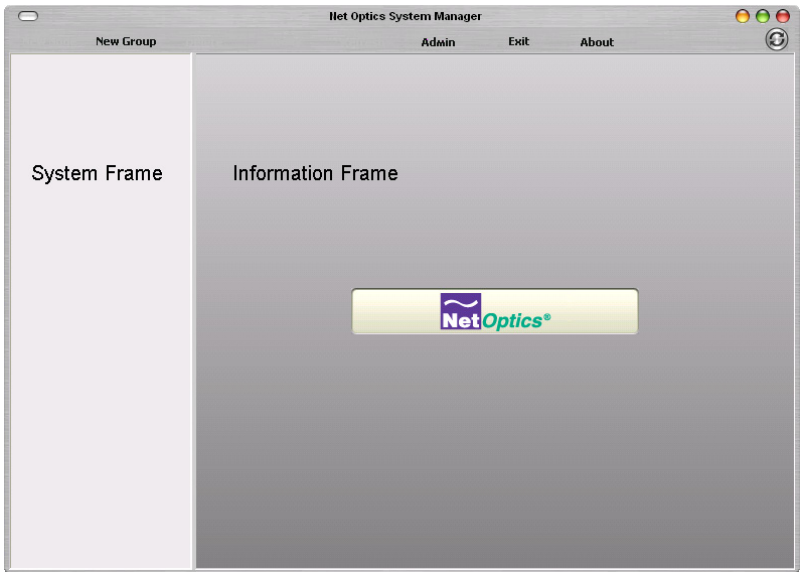

Figure 17: Initial System Manager window

The left side of the window is the System Frame. It displays iTap devices and iTap Groups as you add them to the system. The right side is the Information Frame. It displays Configuration and Status information for individual iTap devices.

Tip!

To use pop-up menu shortcuts, click your right mouse button in the System Frame.

Using the Toolbar

The following figure shows the System Manager toolbar.

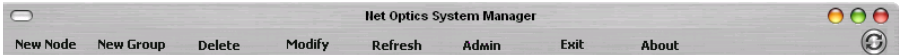

Figure 18: System Manager Toolbar

The table below describes the icons found on the toolbar.

Tool	Description
New Node	Add iTap devices to a group
New Group	Create an iTap group
Delete	Delete an iTap device from the system
Modify	Change the iTap device name, IP address, model, and notes
Refresh	Refresh the data display
Admin	Change the System Manager User Name and Password
Exit	Close Net Optics System Manager
About	View information about System Manager

Create a System Manager Group

You can organize iTap devices into groups for quick access. You must create a Group before you can add iTap devices to your system.

To create an iTap group:

1. Click **New Group** in the toolbar. A new group bar appears in the System Frame as shown in the following figure.

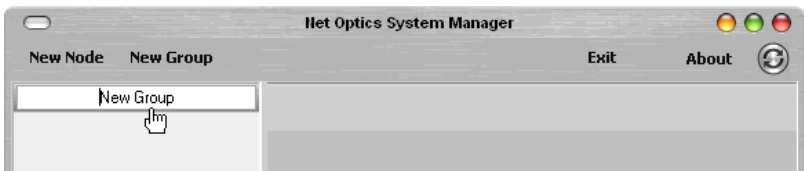

Figure 19: New Group

2. Type the name of the new group and press Enter.

Delete a System Manager Group

You can delete groups you have created. However, be aware that all devices in that group will also be deleted from System Manager.

To delete a Group:

1. Right-click on the group bar of the group you want to delete.
2. Select **Delete** from the menu. The group and all associated devices are deleted from System Manager.

Add Devices to a System Manager Group

To view and control iTap Port Aggregators from System Manager, you must first add each one to a group. Once you have added an iTap device, you can configure, modify, and delete it from System Manager.

To add an iTap device to the system:

1. Select the Group to which you want to add an iTap device by clicking the group bar.
2. Click **New Node** in the toolbar. The New Node dialog box appears.

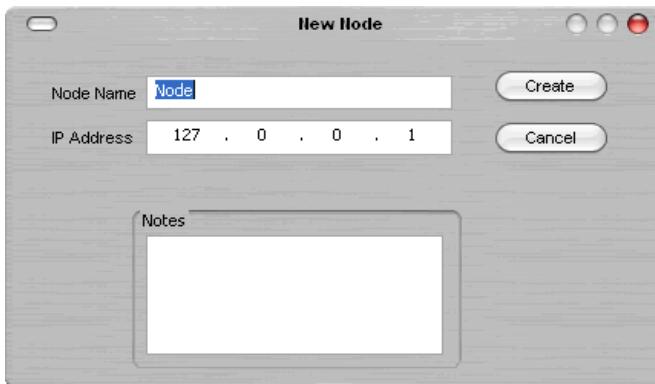

Figure 20: Adding a New Device

3. Enter a name for the device you are adding in the Node Name text box. Each iTap device name in the system must be unique.

4. Enter the IP address of the iTap device in the IP Address text box. Be certain that the IP address is unique on the network.
5. Enter any relevant information about the iTap device in the Notes text box.
6. Check your settings and click **Create**. The device appears in the System Manger system frame.

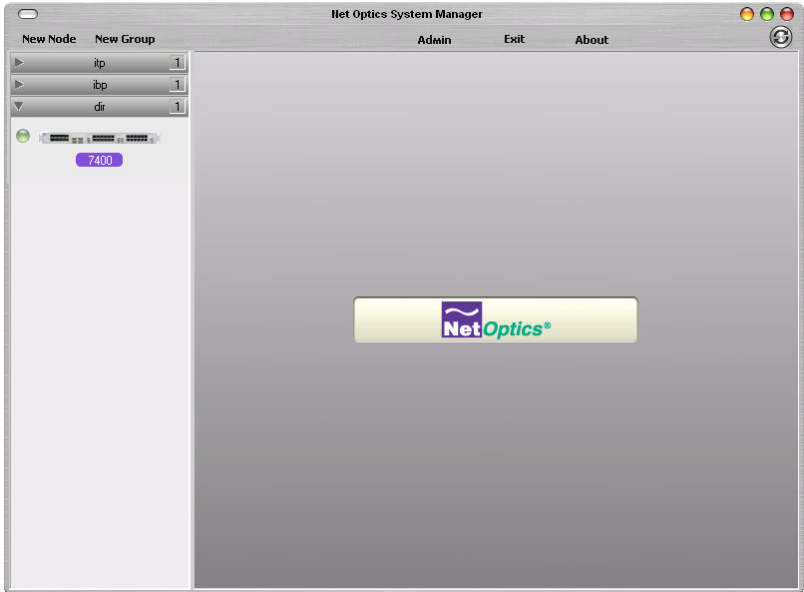

Figure 21: Net Optics System Manager with a device

The indicator to the right of the iTap device picture blinks green when System Manager is communicating with the iTap device. If the indicator blinks red for more than a minute, check that the iTap device is connected to the network and verify the configuration information.

Repeat this procedure for each iTap device you wish to add.

Tip!

To change the display order of iTap devices, click and drag them into the desired order.

Modify an iTap device Name or IP Address

You can change the iTap device name, IP address and Notes from the Modify iTap dialog box.

To modify the iTap device configuration:

1. Select the device you want to modify by clicking its icon in the System Frame.
2. Click **Modify** in the toolbar. The Modify Node dialog box appears.

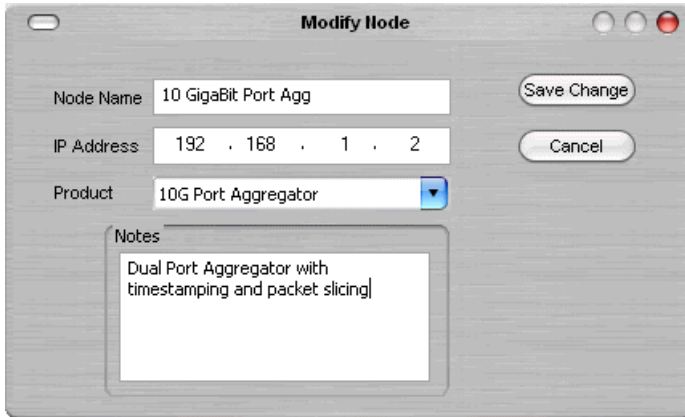

Figure 22: Modify iTap dialog box

3. Make the desired changes and click **Save Change**.

Delete an iTap device from System Manager

When you remove an iTap device from your network, you should delete the device from System Manager. Otherwise, System Manager will continue to poll the iTap device's IP address for data, wasting system resources.

To delete an iTap device from System Manager:

1. Select the device you want to delete by clicking its icon in the System Frame.
2. Click **Delete** in the toolbar. A confirmation dialog box appears.
3. Click **Yes** to delete the iTap device from System Manager.

View iTap Port Aggregator Information

System Manager enables you to view the status of the iTap Port Aggregator, the traffic statistics it collects, and its current device configuration information.

To view iTap Port Aggregator information:

- Select the device you want to view by clicking its icon in the System Frame. A window similar to the figure on the follow page appears. The Status tab is the default view.

The Status tab is a read-only list of information from the iTap device. Use the scroll bar and arrows to view the entire list if it is not all visible on your screen.

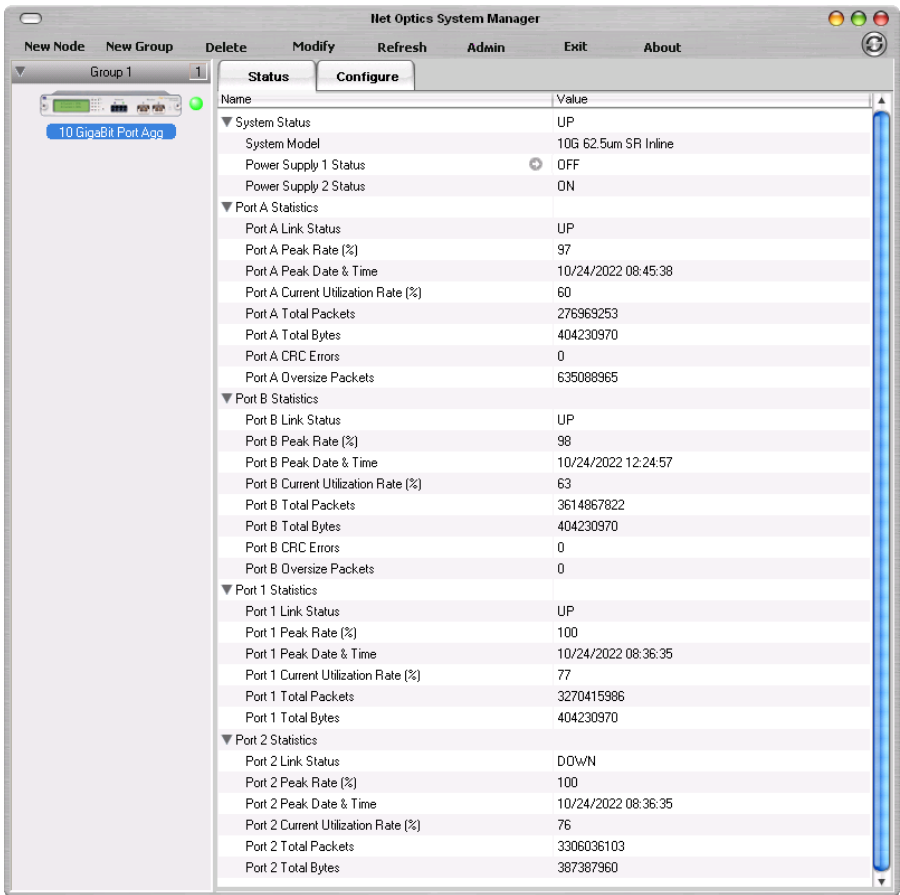

Figure 23: iTap Port Aggregator Status Tab

TIP!

Fields that have been updated since the last refresh appear with a circle and arrow to the left of the value field. For example, see Power Supply 1 Status in Figure 23.

The following table describes the status fields.

Field Name	Value	Description
System Status	UP/DOWN	DOWN indicates an internal error; call Net Optics Customer Service for assistance
System Model	10G 62.5um SR Inline	Identifies the device model
Power Supply 1 Status	ON/OFF	Indicates whether the iTap Port Aggregator is receiving power from Power Supply 1
Power Supply 2 Status	ON/OFF	Indicates whether the iTap Port Aggregator is receiving power from Power Supply 2
Link Status	UP/DOWN	Indicates the state of the communication on the port
Peak Rate (%)	<number>	Highest utilization since last reset
Peak Date & Time	mm/dd/yyyy hr:min:sec	When the peak rate occurred
Current Utilization Rate (%)	<number>	Utilization level of the port bandwidth (incoming traffic on Network Ports, outgoing traffic on Monitor Ports)
Total Packets	<number>	Total packets received
Total Bytes	<number>	Total bytes received
CRC Errors	<number>	Number of CRC errors
Oversize Packets	<number>	Number of oversize packets

Configure an iTap Port Aggregator

Use System Manager's Configure tab to set configuration parameters of an iTap Port Aggregator.

To configure the iTap Port Aggregator:

1. Select the device you want to configure by clicking its icon in the System Frame.
2. Click the **Configure** tab. The configuration information appears.

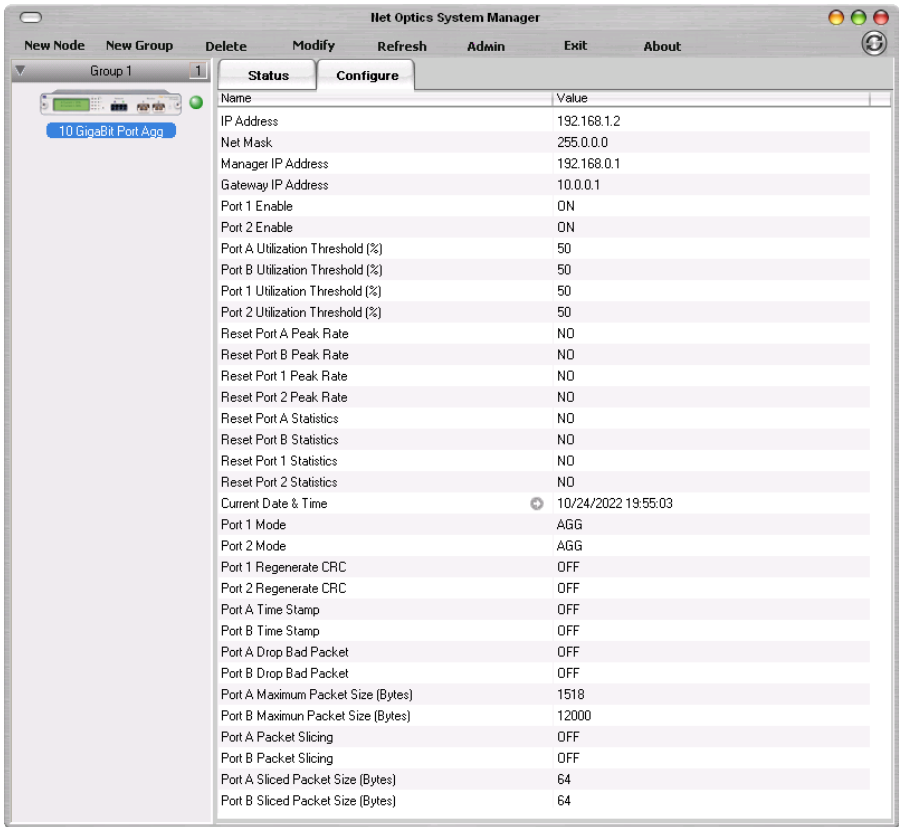

Figure 24: iTap Port Aggregator Configure tab

3. Click on the value corresponding to the parameter you wish to configure.
4. Select an option from the drop-down list, or enter a new value from your keyboard, followed by the Enter key.
5. The new configuration parameters take effect the next time System Manager polls the iTap Port Aggregator.

The following table describes each available configuration option.

Field Name	Description
IP Address	IP address of the iTap. The default IP address is 192.168.1.2. Change the IP address by typing a new IP address in the text box. This is the address for Web Manager and System Manager to communicate with the device.
Net Mask	Displays current Net Mask of the iTap device. The default Net Mask is 255.0.0.0. Change the IP address by typing a new Net Mask in the text box.
Manager IP Address	IP Address of the system management computer running over a WAN. SNMP traps go to this address. Change the IP address by typing a new IP address in the text box.
Gateway IP Address	Displays current IP Address of the current WAN Gateway. Change the Gateway by typing a new IP address in the text box.
Port 1 Enable	Select ON to enable the laser for Monitor Port 1.
Port 2 Enable	Select ON to enable the laser for Monitor Port 2.
Port A Utilization Threshold (%)	Enter the utilization level that will trigger a threshold alarm for Port A.
Port B Utilization Threshold (%)	Enter the utilization level that will trigger a threshold alarm for Port B.
Port 1 Utilization Threshold (%)	Enter the utilization level that will trigger a threshold alarm for Port 1.
Port 2 Utilization Threshold (%)	Enter the utilization level that will trigger a threshold alarm for Port 2.
Reset Port A Peak Rate	Select Yes to reset the Peak data for Port A.
Reset Port B Peak Rate	Select Yes to reset the Peak data for Port B.
Reset Port 1 Peak Rate	Select Yes to reset the Peak data for Port 1.
Reset Port 2 Peak Rate	Select Yes to reset the Peak data for Port 2.
Reset Port A Statistics	Select Yes to zero all counters for Port A.
Reset Port B Statistics	Select Yes to zero all counters for Port B.

Field Name	Description
Reset Port 1 Statistics	Select Yes to zero all counters for Port 1.
Reset Port 2 Statistics	Select Yes to zero all counters for Port 2.
Current Date & Time	The current system time. This clock is used to record the time of traffic utilization peaks.
Port 1 Mode	Select AGG to set Port 1 to aggregation mode. Select TAP to set Port 1 to Tap mode. <i>Note: Both Monitor Ports must always be set to the same mode or the device behavior will be undefined.</i>
Port 2 Mode	Select AGG to set Port 2 to aggregation mode. Select TAP to set Port 2 to Tap mode. <i>Note: Both Monitor Ports must always be set to the same mode or the device behavior will be undefined.</i>
Port 1 Regenerate CRC	Select ON to set Port 1 to append a regenerated CRC to each packet.
Port 2 Regenerate CRC	Select ON to set Port 2 to append a regenerated CRC to each packet.
Port A Timestamp	Select ON to set Port A to timestamp packets.
Port B Timestamp	Select ON to set Port B to timestamp packets.
Port A Drop Bad Packet	Select ON to set Port A to drop packets with CRC errors.
Port B Drop Bad Packet	Select ON to set Port B to drop packets with CRC errors.
Port A Maximum Packet Size (Bytes)	Enter a value from 64 and 12000 to change the value of the maximum packet size on Port A.
Port B Maximum Packet Size (Bytes)	Enter a value from 64 and 12000 to change the value of the maximum packet size on Port B.
Port A Packet Slicing	Select ON to set Port A to packet slice.
Port B Packet Slicing	Select ON to set Port B to packet slice.
Port A Sliced Packet Size (Bytes)	Enter a value from 64 and 12000 to change the number of bytes at which the packet received at Port A is sliced when Port A packet slicing is ON.
Port B Sliced Packet Size (Bytes)	Enter a value from 64 and 12000 to change the number of bytes at which the packet received at Port B is sliced when Port B packet slicing is ON.

Appendix A

Specifications and Models

Specifications

Electrical

Power Supply Input

100-240VAC, 0.5A, 47-63Hz

Power Supply Output

12V, 5A

Environmental

Operating Temperature

0°C to 40°C

Storage Temperature

-10°C to 70°C

Relative Humidity

10% min, 95% max, non-condensing

Mechanical

Dimensions

1.375" high x 11" deep x 8.5" wide

Weight

8 lbs (3.6 kg) maximum, bare unit

10 lbs (4.5 kg) maximum, shipping weight

Indicators

(1) 2x16 Character LCD display

(4) Link LEDs

(4) Threshold Alarm LEDs

(2) Mode LEDs

(2) Power LEDs

Optical Interface

SR Fiber Types

Corning Multimode 62.5/125 μ m, wavelength 850nm

Split Ratio	Network Port Insertion Loss
50/50	~ 3.3 dB

Corning Multimode 50/125 μ m, wavelength 850nm

Split Ratio	Network Port Insertion Loss
50/50	~ 3.3 dB

LR Fiber Type

Corning Singlemode 8.5/125 μ m, wavelength 1310nm

Split Ratio	Network Port Insertion Loss
50/50	~ 3.3 dB

ER Fiber Type

Corning Singlemode 8.5/125 μ m, wavelength 1550nm

Split Ratio	Network Port Insertion Loss
50/50	~ 3.3 dB

Transceiver Specifications

SR 850nm, VCSEL

LR 1310nm, laser

ER 1550nm, laser

Monitor Port Output Power (typical)

SR -5.0 dBm

LR -2.5 dBm

ER 0.5 dBm

Split Ratios

50/50

Software**Command Line Interface**

Any terminal emulation software

Net Optics Web Manager

Any browser

Net Optics System Manager

Windows XP, Windows 2000, Windows 98

Certifications

Fully RoHS compliant

Models and Part Numbers

Part Number	Description
IPA-SR5-XFP	10 Gig SR Multimode, 62.5µm, In-Line
IPA-50SR5-XFP	10 Gig SR Multimode, 50µm, In-Line
IPA-LR5-XFP	10 Gig LR Singlemode, 8.5µm, In-Line
IPA-ER5-XFP	10 Gig ER Singlemode, 8.5µm, In-Line

Note: Span models are also available. See www.netoptics.com.

Appendix B

Command Line Interface

Tip!

The command line interface (CLI) is not case sensitive.

Command	Sub-Command	Syntax	Description
Help	Set	help set	Displays the set command options
	Reset	help reset	Displays the reset command options
	Show	help show	Displays the show command options
	Echo	help echo	Displays the echo command options
Set	IP	set ip <address>	Where <address> is the IP address of the iTap for Web Manager and System Manager
	Netmask	set netmask <address>	Where <address> is the IP address netmask
	Gateway	set gateway <address>	Where <address> is the IP address of the gateway
	Manager	set manager <address>	Where <address> is the IP address of the remote manager for SNMP traps
	Threshold Port	set threshold <port ID> <parameter>	Where <port ID> is A, B, 1, or 2 and <parameter> is 0 to 100% of available bandwidth
	Time	set time <date & time>	Where <date & time> is mm/dd/yyyy-hh:mm:ss
	Display	set display <parameter>	Where <parameter> is 1 = Front panel display on 2 = Front panel display off (other values not applicable) <i>Note: In the OFF state, the display shows "Net Optics, Inc." and the firmware compile date</i>

Command	Sub-Command	Syntax	Description
Set (continued)	Username	set username <username>	Where <username> is the authorized user's name, 32 characters or less
	Password	set password <password>	Where <password> is the authorized user's password, 32 characters or less
	Mgtport	set mgtport <parameter>	Where <parameter> is 1 = Management Port on 2 = Management Port off (other values not applicable)
	Enable Port	set enable port <port ID> <parameter>	Where <port ID> is 1 or 2 and <parameter> is 1 = Monitor Port Laser Enabled 2 = Monitor Port Laser Disabled (other values not applicable)
	Mode Port	set mode port <port ID> <parameter>	Where <port ID> is 1 or 2 and <parameter> is 1 = Tap mode 2 = Aggregation mode (other values not applicable) <i>Note 1: Both Monitor Ports must always be set to the same mode or the device behavior will be undefined.</i> <i>Note 2: When changing from Tap to Aggregation mode, you must change port 2 before you change port 1.</i>
	CRCregen Port	set crcregen port <port ID> <parameter>	Where <port ID> is 1, or 2 and <parameter> is 1 = CRC regeneration on 2 = CRC regeneration off (other values not applicable) Note: CRC regeneration is helpful to make sliced and timestamped packets valid
	Stamp Port	set stamp port <port ID> <parameter>	Where <port ID> is A or B and <parameter> is 1 = Timestamping on 2 = Timestamping off (other values not applicable)

Command	Sub-Command	Syntax	Description
Set (continued)	Dropbad Port	set dropbad port <port ID> <parameter>	Where <port ID> is A or B and <parameter> is 1 = Drop packets with CRC errors 2 = Pass packets with CRC errors (other values not applicable) Note: Applies to CRC errors as the packet is received at the Monitor Port
	Psize Port	set psize port <port ID> <parameter>	Where <port ID> is A or B and <parameter> is 64 to 12000 (other values not applicable) Note: Sets the maximum packet size; packets larger than <psize> are discarded and counted in the oversize packet counter
	Slice Port	set slice port <port ID> <parameter>	Where <port ID> is 1 or 2 and <parameter> is 1 = Packet slicing on 2 = Packet slicing off (other values not applicable)
	Ssize Port	set ssize port <port ID> <parameter>	Where <port ID> is 1 or 2 and <parameter> is 64 to 12000 (other values turn packet slicing OFF) Note: Sets the packet slicing size; only <ssize> bytes are passed when packet slicing is enabled

Command	Sub-Command	Syntax	Description
Reset	Peak Port	reset peak <port ID>	Where <port ID> is A, B, 1 or 2
	Statistics Port	reset statistics port <port ID>	Where <port ID> is A, B, 1 or 2
	Default	reset default	Resets configuration back to factory defaults: Port 1 & 2 Enable = ON Management Port = ON Port Modes = AGG Max Packet Sizes = 1518 Port Slice Sizes = 64 All Set 2 features = OFF
Show	Set	show set <parameter>	Where <parameter> is 1 = Show page 1 2 = Show page 2 [null] = Show pages 1 & 2 Displays current settings
	Status	show status	Displays status of iTap system and ports
	Statistics Port	show statistics port <port ID>	Where <port ID> is A, B, 1, or 2
	Power	show power	Displays power status
	User	show user	Displays current user logged into the CLI
Echo	n/a	echo <parameter>	Where <parameter> is on = Typed characters are displayed on the screen off = Typed characters are not displayed on the screen (other values not applicable)

Limitations on Warranty and Liability

Net Optics offers a limited warranty for all its products. IN NO EVENT SHALL NET OPTICS, INC. BE LIABLE FOR ANY DAMAGES INCURRED BY THE USE OF THE PRODUCTS (INCLUDING BOTH HARDWARE AND SOFTWARE) DESCRIBED IN THIS MANUAL, OR BY ANY DEFECT OR INACCURACY IN THIS MANUAL ITSELF. THIS INCLUDES BUT IS NOT LIMITED TO LOST PROFITS, LOST SAVINGS, AND ANY INCIDENTAL OR CONSEQUENTIAL DAMAGES ARISING FROM THE USE OR INABILITY TO USE THIS PRODUCT, even if Net Optics has been advised of the possibility of such damages. Some states do not allow the exclusion or limitation of implied warranties or liability for incidental or consequential damages, so the above limitation or exclusion may not apply to you.

Net Optics, Inc. warrants this Tap to be in good working order for a period of ONE YEAR from the date of purchase from Net Optics or an authorized Net Optics reseller.

Should the unit fail anytime during the said ONE YEAR period, Net Optics will, at its discretion, repair or replace the product. This warranty is limited to defects in workmanship and materials and does not cover damage from accident, disaster, misuse, abuse or unauthorized modifications.

If you have a problem and require service, please call the number listed at the end of this section and speak with our technical service personnel. They may provide you with an RMA number, which must accompany any returned product. Return the product in its original shipping container (or equivalent) insured and with proof of purchase.

Additional Information

Net Optics, Inc. reserves the right to make changes in specifications and other information contained in this document without prior notice. Every effort has been made to ensure that the information in this document is accurate. Net Optics is not responsible for typographical errors.

THE WARRANTY AND REMEDIES SET FORTH ABOVE ARE EXCLUSIVE AND IN LIEU OF ALL OTHERS, EXPRESS OR IMPLIED. No Net Optics reseller, agent, or employee is authorized to make any modification, extension, or addition to this warranty.

Net Optics is always open to any comments or suggestions you may have about its products and/or this manual.

Send correspondence to
Net Optics, Inc.
5303 Betsy Ross Drive
Santa Clara, CA 95054 USA
Telephone: +1 (408) 737-7777
Fax: +1 (408) 745-7719
Email: info@netoptics.com / Internet: www.netoptics.com

All Rights Reserved. Printed in the U.S.A. No part of this publication may be reproduced, transmitted, transcribed, stored in a retrieval system, or translated into any language or computer language, in any form, by any means, without prior written consent of Net Optics, Inc., with the following exceptions: Any person is authorized to store documentation on a single computer for personal use only and that the documentation contains Net Optics' copyright notice.

www.netoptics.com