

# Installation Guide for Gig Zero Delay™ Tap and 10/100/1000BaseT Tap

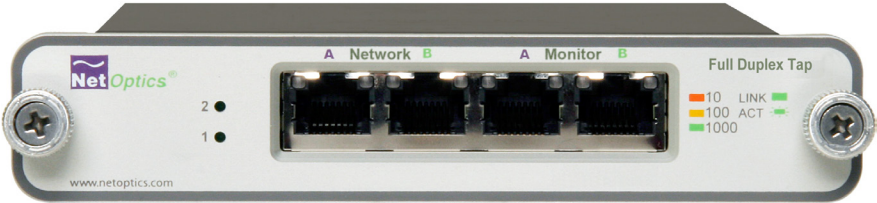
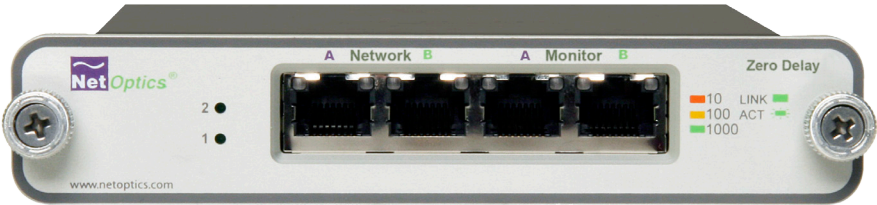

**PLEASE READ THESE LEGAL NOTICES CAREFULLY.**

By using a Net Optics Tap you agree to the terms and conditions of usage set forth by Net Optics, Inc.

No licenses, express or implied, are granted with respect to any of the technology described in this manual. Net Optics retains all intellectual property rights associated with the technology described in this manual. This manual is intended to assist with installing Net Optics products into your network.

***Trademarks and Copyrights***

© 2010 by Net Optics, Inc. Net Optics, Gig Zero Delay, and Link Fault Detect<sup>™</sup> are registered trademarks of Net Optics, Inc. Additional company and product names may be trademarks or registered trademarks of the individual companies and are respectfully acknowledged.

***Additional Information***

Net Optics, Inc. reserves the right to make changes in specifications and other information contained in this document without prior notice. Every effort has been made to ensure that the information in this document is accurate.

---

## Contents

Introduction . . . . .	1
Key Features . . . . .	3
Unpacking and Inspection . . . . .	4
Product Diagrams . . . . .	5
LED Indicators . . . . .	6
Link Fault Detect . . . . .	6
Cabling Guidelines . . . . .	6
Connecting to the Network . . . . .	7
Connecting to the Monitoring Device . . . . .	8
DIP Switch Settings . . . . .	9
Specifications . . . . .	10
Limitations on Warranty and Liability . . . . .	11

---

## **Introduction**

Get total traffic visibility for 10/100/1000 monitoring and security devices by placing Net Optics Gig Zero Delay Taps and 10/100/1000 BaseT Taps on critical network links. These Taps support passive monitoring of 10/100/1000 links at 10, 100, or 1000 Mbps. “Passive” means that network traffic continues to flow even when the Tap does not have any power. These devices are ideal when a passive Tap is required for use with a variety of copper monitoring devices. (The link speed and the monitoring device speed must be the same; the Tap does not perform data rate conversion.)

For superior reliability, these Taps feature Link Fault Detect™ (LFD), which gives the devices connected to the Tap critical information about link status. If either side of the bi-directional link fails, the Tap immediately communicates the fault to both devices, reducing the time required to activate a redundant path.

### **Transparent Access**

The Gig Zero Delay Taps and 10/100/1000 BaseT Taps establish permanent passive access ports without introducing a point of failure or disturbing other network connections. The Gig Zero Delay Tap either auto-negotiates communication or uses an external DIP switch to set fixed speed and duplexing parameters. These passive Taps deliver full-duplex monitoring with zero impact on network traffic around the clock.

### **True Zero Delay**

The breakthrough design of the Net Optics Gig Zero Delay Taps (but not the 10/100/1000 BaseT Taps) ensures zero impact on network traffic when the Tap experiences a power on or power off event. These devices are the world’s first and only 10/100/1000 taps offering true “zero delay” technology.

Highly sensitive network locations can improve monitoring performance with the innovative features of Net Optics Gig Zero Delay Taps. If power is lost to other 10/100/1000 taps, the connected devices may introduce delays as they detect the power loss and try to re-establish their link.

Net Optics’ pioneering design ensures that any loss of power to the Tap is transparent to the network, and does not affect the flow of traffic through the Tap – completely eliminating packet delay and loss as potential security issues.

### **Simply Plug It In**

Full-duplex monitoring is a snap when each side of the signal is sent to a separate NIC on the monitoring device. All network and monitoring cables necessary for plug-and-play deployment are included with the Tap.

### **Security and Visibility**

Without an IP address, monitoring devices are isolated from the network, dramatically reducing their exposure to attacks. However, the monitoring device connected to the Tap still sees all full-duplex traffic as if it were in-line, including Layer 1 and Layer 2 errors.

### **Reliability**

For extra uptime protection, Net Optics Gig Zero Delay Taps and 10/100/1000 BaseT Taps offer redundant power connections. Should the primary power source fail, the Tap automatically switches to the backup power source. Power LEDs on the front of the Tap indicate the current power source.

### **Warning!**

---

*TP-CU3-ZD and TP-CU3-ZD-DC only: This product contains a NiMH battery. Consult your shipping carrier regarding regulations on safe shipping of NiMH batteries.*

---

### **Warning!**

---

*TP-CU3-ZD and TP-CU3-ZD-DC only: Electrical Shock Hazard. No user replaceable parts. Do not open chassis. Return unit to Net Optics for servicing.*

---

### **Note:**

---

*TP-CU3-ZD and TP-CU3-ZD-DC only: Battery Disposal: Dispose of used batteries properly. Contact your local authorities regarding disposal of this battery.*

---

## Key Features

### Passive, Secure Technology

- Provides passive access at 10/100/1000 Mbps without data stream interference or introducing a point of failure
- Unique Zero Delay technology ensures no packet delay or loss if power is lost to the Tap
- Permanent in-line installation without affecting network performance
- Link Fault Detect prevents undetected link failures
- Passes all full-duplex traffic (including errors) from all layers for comprehensive troubleshooting
- No IP address is needed for the Tap or monitoring device, enhancing monitoring security
- Redundant power ensures monitoring uptime
- Fully IEEE 802.3 compliant
- Fully RoHS compliant

### Ease of Use

- LED indicators show redundant power and link status
- DIP switches select auto-negotiation of fixed speed and duplexing settings for the Tap
- Front-mounted connectors make installation and operation quick and easy
- Optional 19-inch rack frames hold up to 3 or 12 Taps
- Available with -48VDC power
- Tested and compatible with all major manufacturers' monitoring devices, including protocol analyzers, probes, and intrusion detection/prevention systems

### Support

- Net Optics offers technical support throughout the lifetime of your purchase. Our technical support team is available from 8 am to 5 pm Pacific Time, Monday through Friday at +1 (408) 737-7777 and by e-mail at [ts-support@netoptics.com](mailto:ts-support@netoptics.com). FAQs are also available on Net Optics website at [www.netoptics.com](http://www.netoptics.com).

## About This Guide

This guide explains how to install the Gig Zero Delay Tap and the 10/100/1000BaseT Tap. Please read the Guide before attempting to install the device.

This guide covers the following models:

- TP-CU3-ZD 10/100/1000 Tap with Zero Delay
- TP-CU3-ZD-DC 10/100/1000 Tap with Zero Delay, -48V DC power
- TP-CU3 10/100/1000 Tap
- TP-CU3-DC 10/100/1000 Tap , -48V DC power

## Unpacking and Inspection

Carefully unpack the Gig Zero Delay Tap and check for damaged or missing parts. The Tap ships with the following:

- (1) Tap device
- (2) power supplies (TP-CU3-ZD and TP-CU3 only)
- (2) power cords (TP-CU3-ZD and TP-CU3 only)
- (1) retainer clip (TP-CU3-ZD and TP-CU3 only)
- (1) network cable, 3 meter, straight-through (purple)
- (1) network cable, 3 meter, cross-over (green)
- (2) monitor cables, 3 meter, straight-through (purple)
- (1) Installation Guide

You may have also ordered a panel for rack mounting and an extended warranty. Carefully check the packing slip against parts received. If any part is missing or damaged, contact Net Optics Customer Service immediately.

## Warning!

---

*For the TP-CU3-ZD and TP-CU3 models, use only the power supplies provided by Net Optics for use with this product. Use of other power supplies may result in a safety hazard that could cause damage or injury.*

---

## Product Diagrams

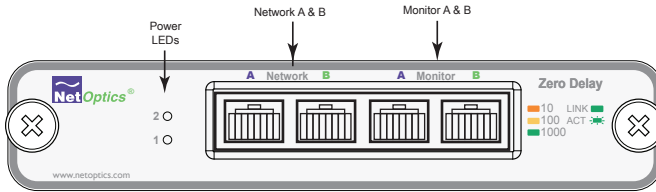

**Figure 1: Front Panel, Gig Zero Delay Taps (TP-CU3-ZD, TP-CU3-ZD-DC)**

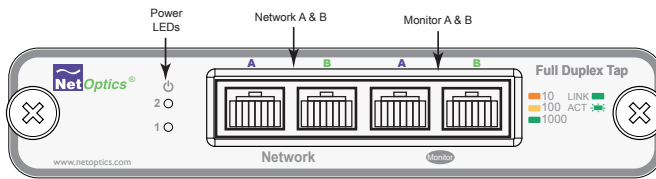

**Figure 2: Front Panel, 10/100/1000BaseT Taps (TP-CU3, TP-CU3-DC)**

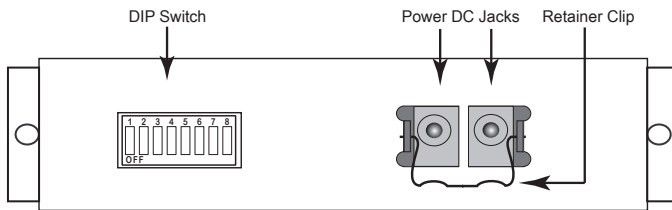

**Figure 3: Rear Panel AC (external transformer "brick") power models**

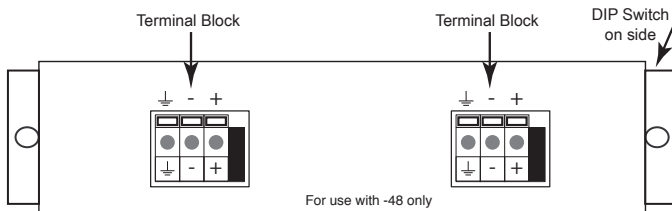

**Figure 4: Rear Panel DC power model TP-CU3-DC**

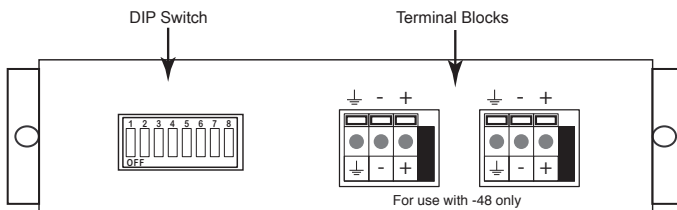
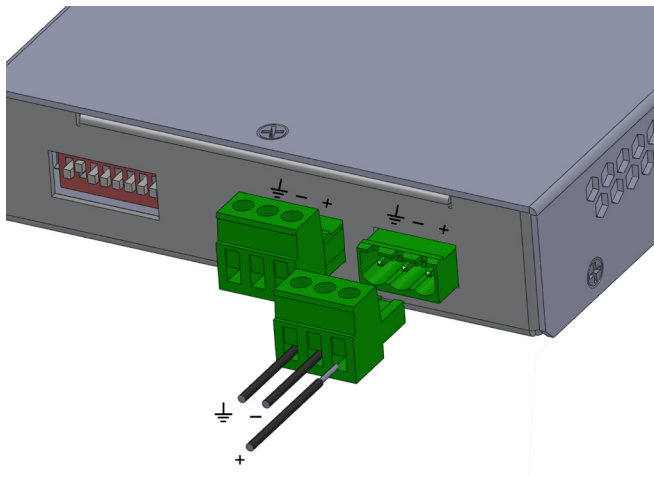

**Figure 5: Rear Panel DC power model TP-CU3-ZD-DC**

## DC Terminal Blocks

Model TP-CU3-DC has screwless terminal blocks for DC power. Push in the orange button to open the socket, insert the power wire, and release the button to clamp the wire into the socket.

Model TP-CU3-ZD-DC has a two piece, screw-type terminal blocks for DC power. you can unplug half of the terminal block for convenience when connecting the power wires. Just pull to unplug the removable part, and push it back in to reconnect it. To connect the power wires, insert a wire into a socket and tighten the screw to hold it in place.



**Figure 6:** Two-piece DC terminal block on model TP-CU3-ZD-DC

### Note:

The symbols  $\perp$  and  $\perp\perp$  both indicate safety ground, also called earth or chassis ground. When attaching the DC power wires, always connect the safety grounds first; and when disconnecting the DC power wires, always disconnect the safety grounds last.

## LED Indicators

- **Power Indicator:** Current power source LED illuminates white.
- **Link/Activity Indicator:** Located in the upper right hand corner. If a good link is established, the LED illuminates. If there is current activity on this link, the LED flashes.
- **10/100/1000 Indicator:** Located in the upper left hand corner. If the Port is set to 10 Mbps, the LED illuminates orange. If the Port is set to 100 Mbps, the LED illuminates yellow. If the Port is set to 1000 Mbps, the LED illuminates green.

## Link Fault Detect™

The Gig Zero Delay Taps and 10/100/1000BaseT Taps have Link Fault Detect on the Network ports. The Tap negotiates separately with each side of the full-duplex link, detecting if either side fails. In the event of a failure, the Tap ceases negotiation with the remaining side, enabling a clean fail-over to a redundant network connection (if one is available). Link Fault Detect requires that both sides of the full-duplex link and communicating at the same speed.

## Cabling Guidelines

If both of the devices connected to the Tap network ports are 10/100BaseT devices that do not support Automatic MDI/MDI-X Configuration, then specific cabling must be used in order to maintain a successful link when power is removed from the Tap. (See explanation, following.) In this case:

- If connecting to Switches or Hubs, use CAT5e RJ45 cross-over cabling.
- If connecting to Routers or NICs, use CAT5e RJ45 straight-through cabling.

### Automatic MDI/MDI-X Configuration

The need for crossover cabling is eliminated by a feature in the 1000Base-T standard called Automatic MDI/MDI-X Configuration (IEEE 802.3-2005, 40.4.4). Ports with this feature detect the positions of the transmit and receive pins, and automatically connect them correctly. All 1000BaseT ports support this feature, as do many 10/100BaseT ports on newer equipment.

The Gig Zero Delay Taps and 10/100/1000BaseT Taps support Automatic MDI/MDI-X Configuration on all of its ports. However, when the Tap does not have power, it passively connects the two network ports so the link remains active. This passive connection is made straight-through. Therefore, if both of the devices connected to the Tap network ports are 10/100BaseT devices that do not support Automatic MDI/MDI-X Configuration, then the positions of the transmit and receive pins cannot be detected automatically, and straight through or crossover cables are required (as specified in the previous list) in order to maintain a successful link.

## Connecting to the Network

To connect the Tap to the Network link:

1. Connect Network Port A to the appropriate switch, server or router using a CAT5e cable.
2. Connect Network Port B to the appropriate switch, server or router using a CAT5e cable.
3. Verify that the Tap Network Ports are cabled in-line between two devices.

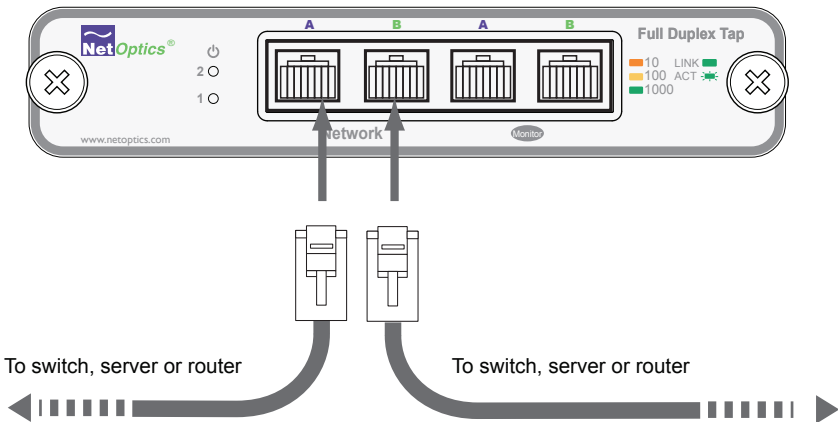

**Figure 7: Connecting to the Network**

**Connecting to the Monitoring Device**

To connect the Tap to the Monitoring device:

1. Supply power to the Tap using the two redundant power supplies included with the unit. Verify that the Power LED illuminates.

**Note:**

*The second power supply is available to support the flow of traffic to the monitoring device in the event that the first power supply becomes unavailable.*

2. Connect Monitor Port A to the appropriate port on the monitoring device using a CAT5e straight-through cable. This cable sends the monitoring device a copy of all of the traffic being received at Monitor Port A.
3. Connect Monitor Port B to the appropriate port on the monitoring device using a CAT5e straight-through cable. This cable sends the monitoring device a copy of all of the traffic being received at Monitor Port B.

**Figure 8: Connecting to the Monitoring Device**

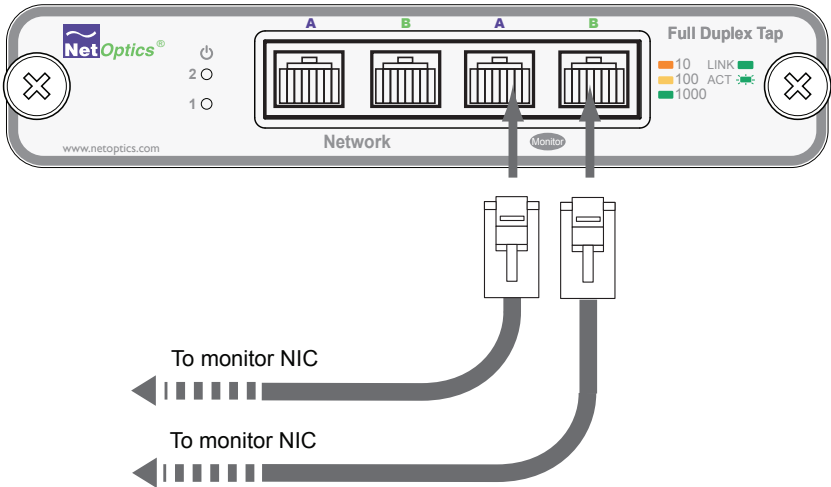

## DIP Switch Settings

The 8-position DIP switch located on the rear panel or the side of the device sets its communication parameters, as specified in the following table.

**Note:**

*The settings apply to all ports on the Tap (except for Switch 1, Link Fault Detect, which applies only to the Network Ports). If you use fixed settings, connected devices must match the settings you select for the Tap.*

Switch	Position	Description
1	ON	Link Fault Detect (LFD) is active on the Network Ports.
	OFF	Link Fault Detect (LFD) is inactive on the Network Ports.
2-5		See following table
6	ON	Full-duplex is active for all ports.
	OFF	Half-duplex is active for all ports. If switch 2 is ON, this switch is ignored
7	-	Reserved
8	OFF	MUST BE OFF

2	3	4	5	Line speed for all ports
ON	X	X	X	Auto-negotiation
OFF	ON	X	X	1000BaseT (Gigabit)
OFF	OFF	ON	X	100BaseT (100Mbps)
OFF	OFF	OFF	ON	10BaseT (10Mbps)
OFF	OFF	OFF	OFF	DO NOT USE

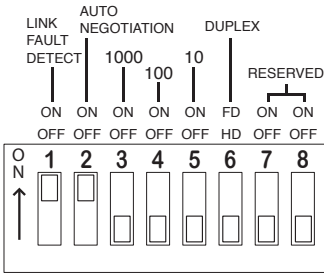

NOTE: To activate, push buttons UP. (This diagram shows all segments in the OFF position)

**Figure 9: DIP Switch Settings**

**Note:**

*If you are using a fixed-speed setting, all devices connected to the Tap should also be set to that same speed. Furthermore, you should set only one speed switch to ON. If more than one speed switch is set to ON, the Tap uses the fastest speed.*

**Note (TP-CU3 & TP-CU3-DC only):**

*Following any modifications to the DIP switch settings, it is necessary to power cycle the Tap for the changes to take affect.*

## Specifications

### Environment

Operating Temperature: 0°C to 40°C

Storage Temperature: -10°C to 70°C (TP-CU3 and TP-CU3-DC)

-10°C to 45°C (TP-CU3-ZD and TP-CU3-ZD-DC)

Relative Humidity: 10% min, 95% max, non-condensing

### Power

Power Consumption, TP-CU3-ZD and TP-CU3-ZD-DC

Maximum: 30 watts

Typical: 8 watts

Power Supply

Input: 100-240VAC, 0.5A, 47-63Hz

Output: 12V 1.5A (TP-CU3 and TP-CU3-DC)

12V 3A (TP-CU3-ZD and TP-CU3-ZD-DC)

-48V Power Supply

Input: -48V DC typical, -36V DC min, -75V DC max

DC Receptacle: Terminal peak, 12-14 gauge wire

### Latency (network-to-network & network-to-monitor)

@ 1000 Mbps: 0.75  $\mu$ sec

@ 100 Mbps: 1.4  $\mu$ sec

@ 10 Mbps: 10  $\mu$ sec

### Mechanical

Dimensions: 1.125" high x 9.9" deep x 5.5" wide

### Cable Interface

Copper Cable Type: CAT5e

Link Distance Supported: 100 meters

### Connectors

(2) RJ45, 8-pin connectors (monitor ports)

(2) RJ45, 8-pin connectors (network ports)

### Certifications

Fully RoHS compliant

Fully IEEE 802.3 compliant

## **Limitations on Warranty and Liability**

Net Optics offers a limited warranty for all its products. IN NO EVENT SHALL NET OPTICS, INC. BE LIABLE FOR ANY DAMAGES INCURRED BY THE USE OF THE PRODUCTS (INCLUDING BOTH HARDWARE AND SOFTWARE) DESCRIBED IN THIS MANUAL, OR BY ANY DEFECT OR INACCURACY IN THIS MANUAL ITSELF. THIS INCLUDES BUT IS NOT LIMITED TO LOST PROFITS, LOST SAVINGS, AND ANY INCIDENTAL OR CONSEQUENTIAL DAMAGES ARISING FROM THE USE OR INABILITY TO USE THIS PRODUCT, even if Net Optics has been advised of the possibility of such damages. Some states do not allow the exclusion or limitation of implied warranties or liability for incidental or consequential damages, so the above limitation or exclusion may not apply to you.

Net Optics, Inc. warrants this Tap to be in good working order for a period of ONE YEAR from the date of purchase from Net Optics or an authorized Net Optics reseller.

Should the unit fail anytime during the said ONE YEAR period, Net Optics will, at its discretion, repair or replace the product. This warranty is limited to defects in workmanship and materials and does not cover damage from accident, disaster, misuse, abuse or unauthorized modifications.

If you have a problem and require service, please call the number listed at the end of this section and speak with our technical service personnel. They may provide you with an RMA number, which must accompany any returned product. Return the product in its original shipping container (or equivalent) insured and with proof of purchase.

### ***Additional Information***

Net Optics, Inc. reserves the right to make changes in specifications and other information contained in this document without prior notice. Every effort has been made to ensure that the information in this document is accurate. Net Optics is not responsible for typographical errors.

THE WARRANTY AND REMEDIES SET FORTH ABOVE ARE EXCLUSIVE AND IN LIEU OF ALL OTHERS, EXPRESS OR IMPLIED. No Net Optics reseller, agent, or employee is authorized to make any modification, extension, or addition to this warranty.

Net Optics is always open to any comments or suggestions you may have about its products and/or this manual.

Send correspondence to  
Net Optics, Inc.  
5303 Betsy Ross Drive  
Santa Clara, CA 95054 USA  
Telephone: +1 (408) 737-7777  
Fax: +1 (408) 745-7719  
Email: [info@netoptics.com](mailto:info@netoptics.com)/[Internet: www.netoptics.com](http://www.netoptics.com)

All Rights Reserved. Printed in the U.S.A. No part of this publication may be reproduced, transmitted, transcribed, stored in a retrieval system, or translated into any language or computer language, in any form, by any means, without prior written consent of Net Optics, Inc., with the following exceptions: Any person is authorized to store documentation on a single computer for personal use only and that the documentation contains Net Optics' copyright notice.

**[www.netoptics.com](http://www.netoptics.com)**