



Installation Guide for 40 GigaBit Fiber Slim Tap



800-0149-001 Rev. B PUBTP40LR5LCSLMU 08/10

Contents

Introduction	1
Key Features	2
About This Guide	3
Unpacking and Inspection	3
Product Diagrams	4
Connecting to the Network	5
Connecting to the Monitoring Device	6
Specifications	7
Limitations on Warranty and Liability	8

PLEASE READ THESE LEGAL NOTICES CAREFULLY.

By using a Net Optics Tap you agree to the terms and conditions of usage set forth by Net Optics, Inc.

No licenses, express or implied, are granted with respect to any of the technology described in this manual. Net Optics retains all intellectual property rights associated with the technology described in this manual. This manual is intended to assist with installing Net Optics products into your network.

Trademarks and Copyrights

© 2010 by Net Optics, Inc. Net Optics® is a registered trademark of Net Optics, Inc. Additional company and product names may be trademarks or registered trademarks of the individual companies and are respectfully acknowledged.

Additional Information

Net Optics, Inc. reserves the right to make changes in specifications and other information contained in this document without prior notice. Every effort has been made to ensure that the information in this document is accurate.

Introduction

Get total traffic visibility for monitoring and security devices by placing Net Optics 40 GigaBit Fiber Taps on critical network links. The all-optical design of the 40 GigaBit Fiber Tap is optimized and tested for high-performance on 40 GigaBit fiber networks. Available for singlemode fiber, 40 GigaBit Fiber Taps support passive monitoring of GigaBit links at 40 Gbps.

Slim Profile

The slim profile of the 40 GigaBit Fiber Tap saves rack space—install up to eight Taps in a one rack unit panel. The all-optical design of the 40 GigaBit Fiber Tap is optimized and tested for high-performance on 40 GigaBit fiber networks.

All Optical Design

Requiring no power, 40 GigaBit Fiber Taps maintain permanent passive access ports without introducing a point of failure or disturbing other network connections. These passive Taps deliver full-duplex monitoring with zero impact on network traffic around the clock.

Simply Plug It In

Depending on your network environment, network and monitoring cable kits may be necessary for deployment. Net Optics' Cable Kits give you all the cables you need to deploy a Net Optics LC Fiber Tap in an LC- or SC- connected environment. Net Optics' custom monitoring cables are used to send each side of the network link to a separate NIC on the monitoring tool for full-duplex monitoring.

Cable Kits are sold separately.

Security and Visibility

Without an IP address, monitoring devices are isolated from the network, dramatically reducing their exposure to attacks. However, the monitoring device connected to the Tap still sees all full-duplex traffic as if it were in-line, including Layer 1 and Layer 2 errors.

Key Features

Passive, Secure Technology

- Provides passive access at 40 Gbps without data stream interference or introducing a point of failure
- All-optical design is optimized and tested for 40 GigaBit fiber networks
- Permanent in-line installation without affecting network performance
- Passes all full-duplex traffic (including errors) from all layers for comprehensive troubleshooting
- No IP address is needed for the Tap or monitoring device, enhancing monitoring security
- Completely transparent to the network and requires no power
- Fully RoHS compliant

Ease of Use

- Front-mounted connectors make installation and operation quick and easy
- Optional 19-inch rack frames hold up to 8 Taps
- Compatible with all major manufacturers' monitoring devices, including protocol analyzers, probes, and intrusion detection/prevention systems

Support

- Net Optics offers free technical support throughout the lifetime of your purchase. Our technical support team is available from 8 am to 5 pm Pacific Time, Monday through Friday at +1 (408) 737-7777 and via email at ts-support@netoptics.com. FAQs are also available on Net Optics website at www.netoptics.com.

About This Guide

Please read the guide before attempting to install 10 GigaBit Fiber Tap. This guide covers the following models:

Part Number	Description
TP40-SM5-LCSLM	40 GigaBit Singlemode Fiber Slim Tap (LR4)

Unpacking and Inspection

Carefully unpack the 40 GigaBit Fiber Tap and check for damaged or missing parts. The Fiber Tap ships with the following:

- 40 GigaBit Fiber Slim Tap
- Test report
- Installation Guide

You may have also ordered a panel for rack mounting and an extended warranty. Carefully check the packing slip against parts received. If any part is missing or damaged, contact Net Optics' Customer Service immediately.

Product Diagram

Figure 1: TP40-LR5-LCSLM Front Panel

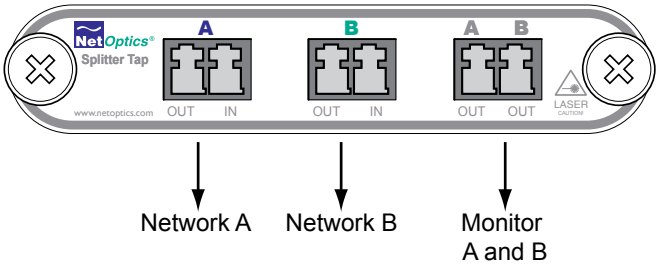

Connecting to the Network

- 1. Connect Network Port A to the appropriate network device using a Duplex LC cable.
- 2. Connect Network Port B to the appropriate network device using a Duplex LC cable.
- 3. Verify that the Tap Network Ports are cabled in-line between two devices.

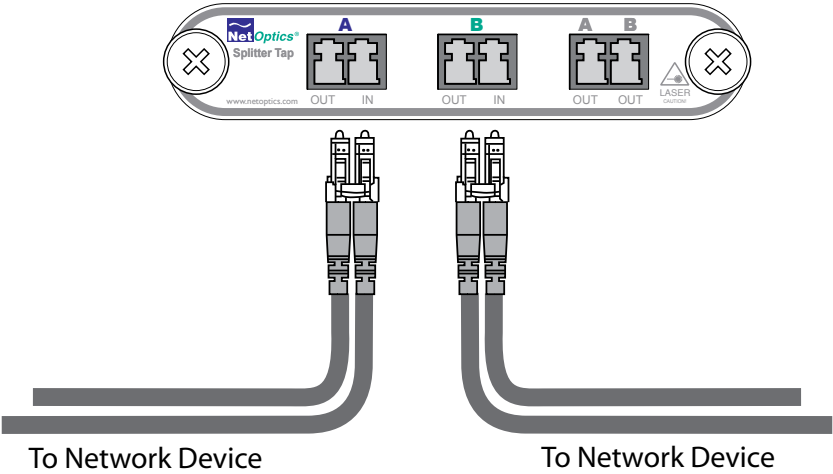

Figure 3: Connecting to the Network

Connecting to the Monitoring Device

1. Connect to the Monitor Port using a Duplex LC cable.
2. Connect the Monitor Port to the appropriate monitoring device using a Duplex LC cable.
3. Verify that the Tap Monitor Port is cabled to the monitoring device.

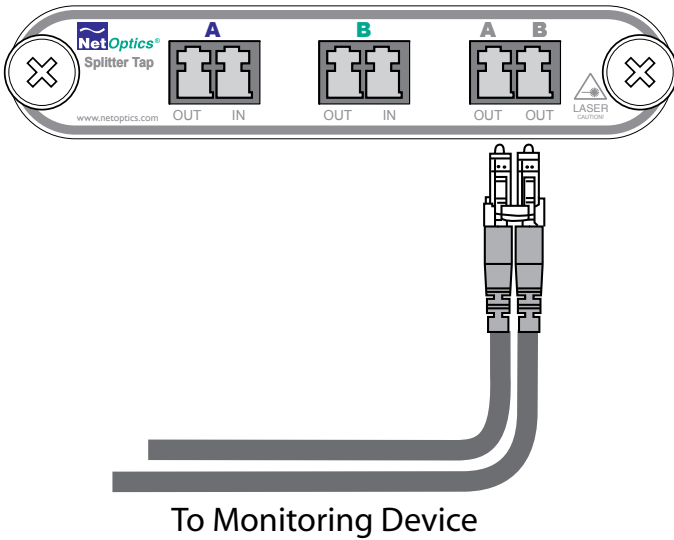

Figure 4: Connecting the Monitoring Device

Specifications

Splitter Specifications

Fiber Type:

Corning Singlemode 8.5/125 μ m, wavelength 1310nm

Split Ratio	Network Port Insertion Loss	Monitor Port Insertion Loss
50/50	≤ 3.5 dB	≤ 3.5 dB

Environment

Operating Temperature: 0°C to 40°C

Storage Temperature: -55°C to 85°C

Relative Humidity: 10% min, 95% max, non-condensing

Mechanical

Dimensions: 0.8" high x 5.5" deep x 4" wide

Connectors

(1) Duplex LC connector (monitor port)

(2) Duplex LC connectors (network ports)

Certifications

Fully RoHS compliant

Limitations on Warranty and Liability

Net Optics offers a limited warranty for all its products. IN NO EVENT SHALL NET OPTICS, INC. BE LIABLE FOR ANY DAMAGES INCURRED BY THE USE OF THE PRODUCTS (INCLUDING BOTH HARDWARE AND SOFTWARE) DESCRIBED IN THIS MANUAL, OR BY ANY DEFECT OR INACCURACY IN THIS MANUAL ITSELF. THIS INCLUDES BUT IS NOT LIMITED TO LOST PROFITS, LOST SAVINGS, AND ANY INCIDENTAL OR CONSEQUENTIAL DAMAGES ARISING FROM THE USE OR INABILITY TO USE THIS PRODUCT, even if Net Optics has been advised of the possibility of such damages. Some states do not allow the exclusion or limitation of implied warranties or liability for incidental or consequential damages, so the above limitation or exclusion may not apply to you.

Net Optics, Inc. warrants this Tap to be in good working order for a period of ONE YEAR from the date of purchase from Net Optics or an authorized Net Optics reseller.

Should the unit fail anytime during the said ONE YEAR period, Net Optics will, at its discretion, repair or replace the product. This warranty is limited to defects in workmanship and materials and does not cover damage from accident, disaster, misuse, abuse or unauthorized modifications.

If you have a problem and require service, please call the number listed at the end of this section and speak with our technical service personnel. They may provide you with an RMA number, which must accompany any returned product. Return the product in its original shipping container (or equivalent) insured and with proof of purchase.

Additional Information

Net Optics, Inc. reserves the right to make changes in specifications and other information contained in this document without prior notice. Every effort has been made to ensure that the information in this document is accurate. Net Optics is not responsible for typographical errors.

THE WARRANTY AND REMEDIES SET FORTH ABOVE ARE EXCLUSIVE AND IN LIEU OF ALL OTHERS, EXPRESS OR IMPLIED. No Net Optics reseller, agent, or employee is authorized to make any modification, extension, or addition to this warranty.

Net Optics is always open to any comments or suggestions you may have about its products and/or this manual.

Send correspondence to
Net Optics, Inc.
5303 Betsy Ross Drive
Santa Clara, CA 95054 USA
Telephone: +1 (408) 737-7777
Fax: +1 (408) 745-7719
Email: info@netoptics.com/Internet: www.netoptics.com

All Rights Reserved. Printed in the U.S.A. No part of this publication may be reproduced, transmitted, transcribed, stored in a retrieval system, or translated into any language or computer language, in any form, by any means, without prior written consent of Net Optics, Inc., with the following exceptions: Any person is authorized to store documentation on a single computer for personal use only and that the documentation contains Net Optics' copyright notice.

www.netoptics.com