

Installation Guide for GigaBit Fiber Media Converter

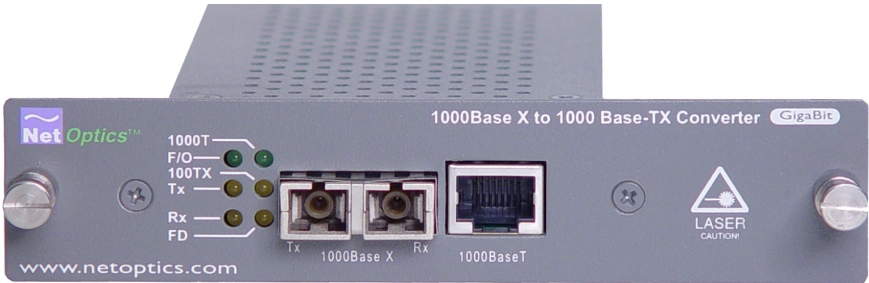

Contents

Introduction	1
Key Features	1
Auto-negotiation Notes	2
Product Diagrams	3
Connecting the GigaBit Media Converter to the Network	4
Safety Notes on Laser Singlemode and Multimode-type Connectors	7
GigaBit Ethernet Connection Distances	8
Specifications	9
Limitations on Warranty and Liability	10

PLEASE READ THESE LEGAL NOTICES CAREFULLY.

By using a Net Optics GigaBit Media Converter you agree to the terms and conditions of usage set forth by Net Optics, Inc.

No licenses, express or implied, are granted with respect to any of the technology described in this manual. Net Optics retains all intellectual property rights associated with the technology described in this manual. This manual is intended to assist application in installing Net Optics products into your network.

Trademarks and Copyrights

© 2007 by Net Optics, Inc. Net Optics® is a registered trademark of Net Optics, Inc. Additional company and product names may be trademarks or registered trademarks of the individual companies and are respectfully acknowledged.

Additional Information

Net Optics, Inc. reserves the right to make changes in specifications and other information contained in this document without prior notice. Every effort has been made to ensure that the information in this document is accurate.

Introduction

Net Optics GigaBit SX/TX and LX/TX Converters are simple and reliable devices for connecting GigaBit copper traffic and GigaBit fiber devices and links. Use these bi-directional media converters individually to connect GigaBit copper and GigaBit fiber devices, or in pairs at each end of long-distance fiber links. These Converters are the perfect solution for dispersed networks where media conversion required between copper network segments separated by long distances.

Fast and Versatile

The GigaBit SX/TX and LX/TX Converters support seamless media conversion of optical signals for data rates at 1000 Mbps, over a full link distance of 220 meters (62.5/125 μ m multimode fiber), 550 meters (50/125 μ m multimode fiber) or 10 kilometers (8.5/125 μ m singlemode fiber). The CV-SX/GCU model supports transmission over either 62.5 μ m or 50 μ m multimode fiber. The Converter supports either full or half-duplex transmission with optional auto-negotiation over the fiber link and UTP port.

Fault Tolerant and Reliable

Net Optics GigaBit SX/TX and LX/TX Converters incorporate Link Fault Signaling, which gives the devices connected to the Converter critical information about link status. If either side of the bi-directional link fails, the Converter immediately communicates the fault to both devices, reducing the time required to activate a redundant path. To control jitter over long optical links, the Converter features Clock and Data Recovery (CDR). CDR ensures that the overall jitter budget is not exceeded when deploying converter pairs with long fiber links.

For extra uptime protection, Net Optics Converters offer redundant power connections. Should the primary power source fail, the Converter automatically switches to the backup power source.

Key Features

Passive, Secure Technology

- Provides transparent conversion at 1000 Mbps without data stream interference
- Link Fault Signaling provides critical information about link status

Passive, Secure Technology (continued)

- Clock and Data Recovery (CDR) control overall jitter when deploying converter pairs
- Redundant power ensures monitoring uptime
- Enables auto-negotiation, or fixed speed and duplexing settings for both copper and fiber sides
- Compatible with all singlemode and multimode fibers
- Fully IEEE 802.3 Compliant
- Fully RoHS Compliant

Ease of Use

- LED indicators show link status and redundant power
- Front-mounted connectors support easy installation and operation
- Optional 19-inch rack frames hold up to 3 or 12 Taps
- Tested and compatible with all major manufacturers' monitoring devices, including protocol analyzers, probes, and intrusion detection/prevention systems

Support

- Net Optics offers free technical support throughout the lifetime of your purchase. Our technical support team is available from 8 am to 5 pm Pacific Time, Monday through Friday at +1 (408) 737-7777 and via email at ts-support@netoptics.com. FAQs are also available on Net Optics website at www.netoptics.com.

Auto-negotiation Notes

1. The CV-SX/GCU and CV-LX/GCU units enable optional auto-negotiation over the connected fiber link in conjunction with the existing UTP port auto-negotiation. The control switch is located at the side of the unit.
2. When the Fiber Port Negotiation function is turned-on [the default position], it allows the MAC [media access control] behind the other connected device's fiber port to "see" the converter's copper port auto-negotiation with its link partner and participate in the end-to-end negotiation process. This will tend to eliminate opposite ends of a series of copper/fiber segments negotiating/defaulting to different service levels.
3. When the Fiber Port Negotiation function is turned-off, standard copper port, auto-negotiation between the converter and the other connected devices is allowed. The converter's fiber port will transparently forward all traffic. This is appropriate when the converter is connected to older equipment without fiber auto-negotiation present or turned-on.

Product Diagrams

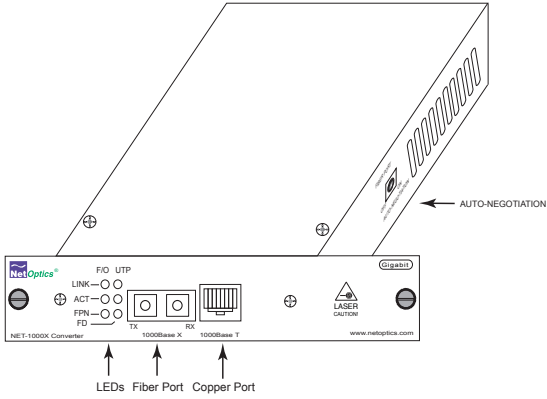

Figure 1: Rack-mount model

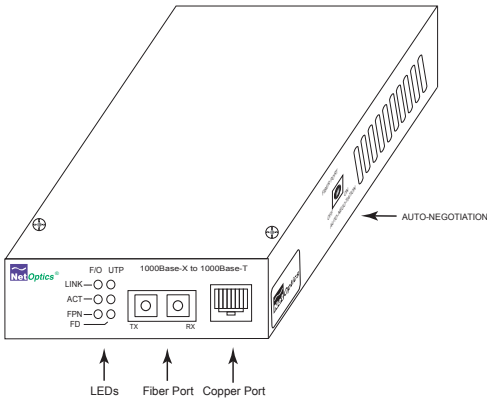

Figure 2: Stand-alone model

Connecting the GigaBit Media Converter to the Network

Connecting the GigaBit Fiber Port to the Network:

1. Unpack the GigaBit Media Converter, verify that you have all components, and obtain the required cables needed to successfully install the unit.
2. Using a duplex SC cable, connect the appropriate switch, server, or router to the GigaBit Media Converter's fiber port.
The use of singlemode or multimode cabling is determined by the GigaBit media Converter model purchased.

Note:

For connections with legacy devices, where Fiber Port negotiation is not present, it will be necessary to disable the toggle switch (FPN) on the side of the unit and power cycle the tap.

Multimode 1000BaseSX ports on CV-SX/GCU Series converters are connected via standard 50/125 μm , 62.5/125 μm or 100/140 μm multimode fiber. Singlemode 1000BaseLX ports are connected by 8.5 μm singlemode fiber. Singlemode 1000BaseLX ports also may be used to increase the transmission distance over multimode fiber cable.

When installing the GigaBit Media Converter, care must be taken in choosing the appropriate cabling to avoid Differential Mode Delay (DMD) effects. DMD is caused by singlemode, (1310 nanometer) laser point sources launching into multimode cable. Optical power is concentrated in the center of the fiber core, propagating in less than 5% of possible modal paths. This can result in reduced bandwidth and/or the appearance of individual data pulses, refracting into multiple, overlapping light pulses at the receiver end, therefore causing CRC errors.

The connection requires a Mode Conditioning patch cable to provide the Conditioned Launch necessary to prevent (DMD) effects. Mode Conditioning patch cables are not used with short wave length (850 nano-meter) lasers. Note that fiber cable is typically certified for a particular bandwidth using light emitting diodes (LEDs) that provide the "Overfilled Launch" condition i.e. illuminate all possible modes and fibers.

For additional details see the [Restricted Launch Specification](#) defined by the Telecommunications Industry Association. The TIA FO-2.2.1 Committee has released two standards: (1) FOTP-203: Launched Power Distribution Measurement Procedure for Graded-Index Multimode Fiber Transmitters, and (2) FOTP-204: Measurement of Bandwidth on Multimode Fiber.

Connecting the GigaBit Media Converter to the Network

Connecting the GigaBit Copper Port to the Network

1. Using a CAT5e cable, connect the appropriate switch, server to the GigaBit Media Converter's copper port.
2. Supply power to the GigaBit Media Converter using the two power supplies included with the unit.
3. Compare the LEDs on the Media Converter to the information below to verify correct setup.
 - **PWR:** Power. Main/Redundant power LED illuminates green when device is powered on (Located on rear of unit).
 - **F/O Link:** Illuminates green when a good fiber optic link is established
 - **UTP Link:** Illuminates green when a good UTP link is established.
 - **F/O ACT:** Illuminates green when activity on the fiber optic link is established.
 - **UTPACT:** Illuminates green when activity on the UTP link is established.
 - **FPN:** Illuminates green when fiber auto-negotiation switch is set to an on position.
 - **FD:** Illuminates green when full duplex traffic is present.

Note:

The CV-SX/GCU converter detects the incoming signal and automatically makes the correct MDI (straight) or MDI-X (crossover) configuration selection. Cable/connector conflicts can be ignored.

When lit, the 100 TX LED only shows that a 100BaseT source has been connected to the GigaBit UTP port. Although showing a link, the connection will be non-functional. A 100BaseT (100Mbs) data stream is too slow for the GigaBit fiber-optic driver circuit to process. Net Optics GigaBit Media Converters only operate successfully at GigaBit data rates.

Connecting the GigaBit Media Converter to the Network

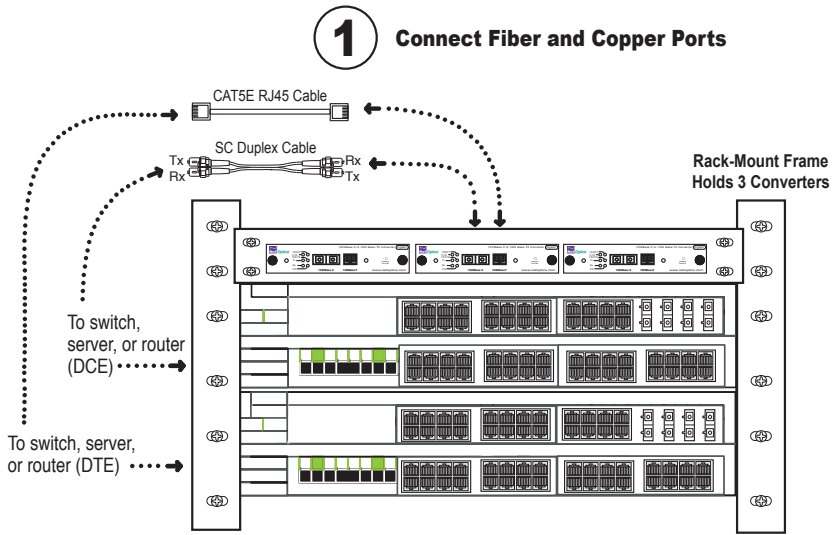

Figure 3: Connecting to the Network

Safety Notes on Laser Singlemode and Multimode-type Connectors

The CV-LX/GCU uses (invisible) 1310 nm wavelength, eye-safe type, laser, singlemode connectors.

The CV-SX/GCU uses (visible) 850 nm wave length, eye-safe type, laser multimode connectors.

Observe caution when deploying equipment using laser optics. **Non**-eye safe laser devices may be inadvertently connected to cabling that is intended to be attached to eye-safe 850 nm or 1300 nm laser driven equipment. This poses a risk for eye and equipment damage. All fiber optic cables (connectors) that are or may be connected to a laser source should be clearly labeled and **assumed** to be connected to non-eye safe laser optics.

Note:

*Do not connect **non**-eye safe laser devices to eye-safe class equipment. **Non**-eye safe laser driven devices, besides damaging eye sight, can permanently damage eye-safe (low-power laser) rated equipment. Such damage will **not** be covered by warranty. Net Optics, Inc. disclaims all liability for damages arising from mis-use or incorrect installation of laser driven equipment.*

CAUTION: NEVER ATTEMPT TO VERIFY ANY FIBER OPTIC CONNECTION BY LOOKING DIRECTLY INTO A FIBER-OPTIC PORT OR CABLE. IF THE LIGHT SOURCE IS A NON-EYE SAFE, LASER EMITTER, PERMANENT EYE DAMAGE MAY RESULT.

NEVER LOOK INTO THE BORE OF A FIBER OPTIC CONNECTOR!

GigaBit Ethernet Connection Distances

CV-SX/GCU (850 nm laser)

Fiber Core Diameter	Type	Fiber Bandwidth Mhz/km	Distance
62.5 μm	Multimode	160 Mhz/km	2 to 220 m
62.5 μm	Multimode	200 Mhz/km	2 to 275 m
50.0 μm	Multimode	400 Mhz/km	2 to 500 m
50.0 μm	Multimode	500 Mhz/km	2 to 550 m

CV-LX/GCU (1310 nm laser)

Fiber Core Diameter	Type	Fiber Bandwidth Mhz/km	Distance
62.5 μm	Multimode*	500 Mhz/km	2 to 550 m
62.5 μm	Multimode*	400 Mhz/km	2 to 550 m
50.0 μm	Multimode*	500 Mhz/km	2 to 550 m
8.5 μm	Singlemode	n/a	2 to 5000 m

Note:

These fiber types require a patch cable for a conditioned launch.

Specifications

Environmental

Operating Temperature: 0°C to 55°C
Storage Temperature: -10°C to 70°C
Relative Humidity: 5% min, 95% max, non-condensing

Mechanical

Power Supply: Input: 100-240 VAC, 0.6A, 50-60 Hz
(AC100-125V~30VA, 50-60 Hz, for Japan)
Output: 5V, 2A (5V, 2.4A for UK and Japan)
Dimensions: 1.0" high x 5.3" deep x 2.9" wide

Connectors

(1) Duplex SC connector
(1) RJ45, 8 pin connector

Optical Interface

Multimode (CV-SX/GCU):

Fiber Type: Multimode Corning 62.5/125 μ m, wavelength 850nm or
Multimode Corning 50/125 μ m, wavelength 850nm
Transceiver: Class I, eye-safe, laser emitter type. These Class I Lasers conform to the applicable requirements per US 21 CFR (J) and EN 60825-1, also UL 1950 applications.
Optical Transmitter Wave Length: 850 nm nominal
Output Power: -9.5 dB min, -4 dB max
Optical Receiver Input Sensitivity: 0 dB min, -17 dB max

Singlemode (CV-LX/GCU):

Fiber Type: Singlemode Corning 8.5/125 μ m, wavelength 1310nm
Transceiver: Class I, eye-safe, laser emitter type. These Class I Lasers conform to the applicable requirements per US 21 CFR (J) and EN 60825-1, also UL 1950 applications.
Optical Transmitter Wave Length: 1310 nm nominal
Output Power: -13 dB min, -3 dB max
Optical Receiver Input Sensitivity: -3 dB min, -20 dB max

Certifications

Full RoHS compliant

Limitations on Warranty and Liability

Net Optics offers a limited warranty for all its products. IN NO EVENT SHALL NET OPTICS, INC. BE LIABLE FOR ANY DAMAGES INCURRED BY THE USE OF THE PRODUCTS (INCLUDING BOTH HARDWARE AND SOFTWARE) DESCRIBED IN THIS MANUAL, OR BY ANY DEFECT OR INACCURACY IN THIS MANUAL ITSELF. THIS INCLUDES BUT IS NOT LIMITED TO LOST PROFITS, LOST SAVINGS, AND ANY INCIDENTAL OR CONSEQUENTIAL DAMAGES ARISING FROM THE USE OR INABILITY TO USE THIS PRODUCT, even if Net Optics has been advised of the possibility of such damages. Some states do not allow the exclusion or limitation of implied warranties or liability for incidental or consequential damages, so the above limitation or exclusion may not apply to you.

Net Optics, Inc. warrants this GigaBit Media Converter to be in good working order for a period of ONE YEAR from the date of purchase from Net Optics or an authorized Net Optics reseller.

Should the unit fail anytime during the said ONE YEAR period, Net Optics will, at its discretion, repair or replace the product. This warranty is limited to defects in workmanship and materials and does not cover damage from accident, disaster, misuse, abuse or unauthorized modifications.

If you have a problem and require service, please call the number listed at the end of this section and speak with our technical service personnel. They may provide you with an RMA number, which must accompany any returned product. Return the product in its original shipping container (or equivalent) insured and with proof of purchase.

THE WARRANTY AND REMEDIES SET FORTH ABOVE ARE EXCLUSIVE AND IN LIEU OF ALL OTHERS, EXPRESS OR IMPLIED. No Net Optics reseller, agent, or employee is authorized to make any modification, extension, or addition to this warranty.

Net Optics is always open to any comments or suggestions you may have about its products and/or this manual.

Send correspondence to
Net Optics, Inc.
5303 Betsy Ross Drive
Santa Clara, CA 95054 USA
Telephone: +1 (408) 737-7777
Fax: +1 (408) 745-7719
Email: info@netoptics.com
Internet: www.netoptics.com

All Rights Reserved. Printed in the U.S.A. No part of this publication may be reproduced, transmitted, transcribed, stored in a retrieval system, or translated into any language or computer language, in any form, by any means, without prior written consent of Net Optics, Inc., with the following exceptions: Any person is authorized to store documentation on a single computer for personal use only and that the documentation contains Net Optics' copyright notice.

www.netoptics.com