



Installation Guide for Optical Bypass Switch



Contents

Introduction	1
Key Features	2
Product Diagrams	3
About this Guide	4
Unpacking and Inspection	4
Power Loss Bypass	5
Connecting to the Network	7
Connecting to the In-line Security Device	8
Specifications	9
Limitations on Warranty and Liability	10

PLEASE READ THESE LEGAL NOTICES CAREFULLY.

By using a Net Optics Optical Bypass Switch you agree to the terms and conditions of usage set forth by Net Optics, Inc.

No licenses, express or implied, are granted with respect to any of the technology described in this manual. Net Optics retains all intellectual property rights associated with the technology described in this manual. This manual is intended to assist with installing Net Optics products into your network.

Trademarks and Copyrights

© 2010 by Net Optics, Inc. Net Optics® is a registered trademark of Net Optics, Inc. Additional company and product names may be trademarks or registered trademarks of the individual companies and are respectfully acknowledged.

Additional Information

Net Optics, Inc. reserves the right to make changes in specifications and other information contained in this document without prior notice. Every effort has been made to ensure that the information in this document is accurate.

Introduction

Net Optics Optical Bypass Switches provide a permanent and trouble-free access port for in-line network security and monitoring devices. The Optical Bypass Switch automatically switches network traffic through added in-line devices or bypasses devices that are about to be removed. Prevent link failure when attached IPS and IDS devices lose power by powering the Bypass Switch and in-line device from the same power source.

Uninterrupted traffic

The Optical Bypass Switch supports fail-open monitoring with any fiber in-line device when it shares the same power source as the in-line appliance. While the Optical Bypass Switch is receiving power, it diverts network traffic to attached in-line devices. In this state, all in-line traffic is routed directly to the device connected to the Optical Bypass Switch.

When the Optical Bypass Switch loses power, in-line traffic continues to flow through the network link, but is no longer routed through the device. This allows the network devices to be removed and replaced without network downtime. Once power is restored to the Optical Bypass Switch, network traffic is seamlessly diverted to the in-line device, allowing it to resume its critical functions.

Simply Plug It In

Each Bypass Switch includes all the cables and power supplies you need to quickly connect to an IPS. Three quick steps is all it takes to establish a secure connection point for inline devices.

Key Features

Passive, Secure Technology

- Fail-open monitoring with any GigaBit fiber in-line appliance at speeds of 1000 Mbps
- Increased reliability on critical network links
- High-speed optical switching with minimal insertion loss
- Fully RoHS compliant

Ease of Use

- LED indicator shows power status
- Front-mounted connectors support easy installation and operation
- Cables included for plug-and-play deployment
- Silk-screened application diagram illustrates all connections for easy deployment
- Optional 19-inch rack frames holds two Bypass Switches
- Tested and compatible with all major manufacturers' monitoring devices, including protocol analyzers, probes, and intrusion detection/prevention systems

Support

- Net Optics offers free technical support throughout the lifetime of your purchase. Our technical support team is available from 8 am to 5 pm Pacific Time, Monday through Friday at +1 (408) 737-7777 and via email at ts-support@netoptics.com. FAQs are also available on Net Optics website at www.netoptics.com.

Product Diagrams

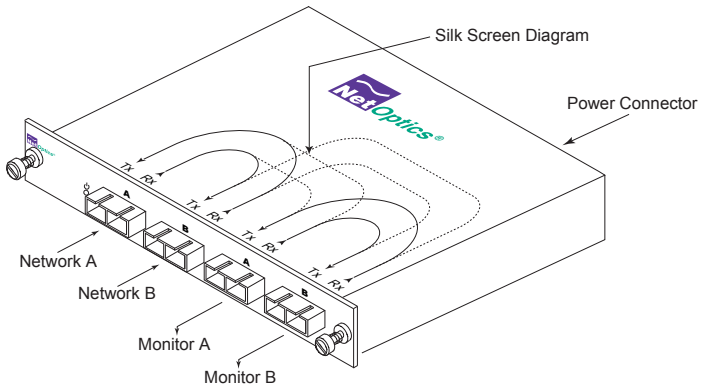

Figure 1. BPO-SX and BPO-LX models with DC Jack

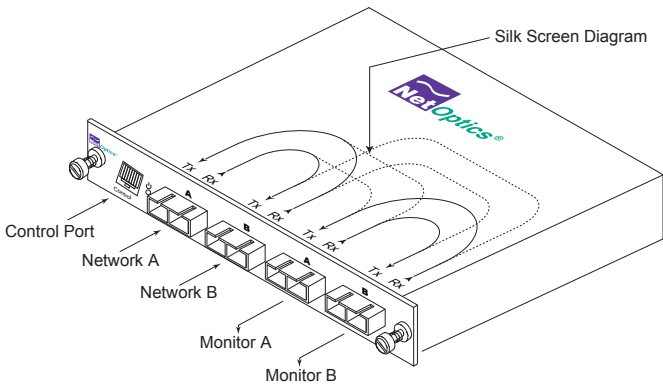

Figure 2. BPO-SX-1 and BPO-LX-1 models with RJ45 port

About this Guide

This guide covers the installation and use of the following models:

Part Number	Description
BPO-SX	Optical Bypass Switch, Multimode
BPO-LX	Optical Bypass Switch, Singlemode
BPO-SX-1	Optical Bypass Switch, Multimode w/RJ45
BPO-LX-1	Optical Bypass Switch, Singlemode w/RJ45

Unpacking and Inspection

Unpack the Optical Bypass Switch, power supply, and cables provided. Each Optical Bypass Switch is delivered with the following:

- 1 Control cable (BPO-SX-1, BPO-LX-1 models)
or
- 1 DC power supply (BPO-SX, BPO-LX models)
- 2 Duplex SC fiber cables
- 1 Manual

If any component is missing or damaged, contact Net Optics Customer Service immediately.

Power Loss Bypass

The Optical Bypass Switch protects link integrity when the in-line appliance loses power. When the Bypass Switch is receiving power it is in Bypass Disabled (OFF) mode. In Bypass Disabled mode the switch sends network traffic through the connected device.

Bypass Disabled Mode

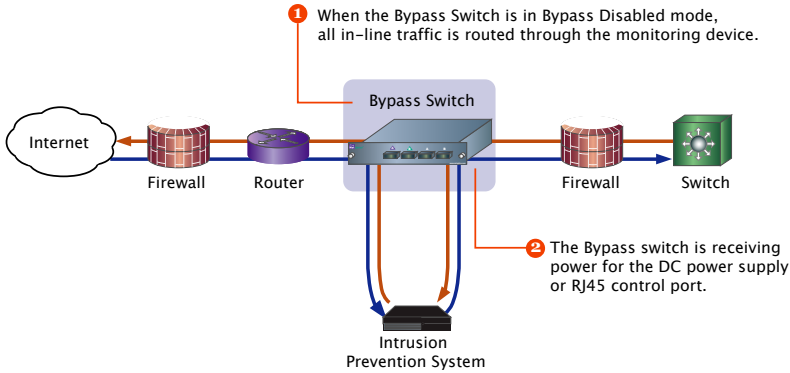

Figure 3. Disabled Mode

When power to switch fails, it enters Bypass Enabled (ON) mode and network traffic bypasses the connected device until power to the switch is restored.

Bypass Enabled Mode

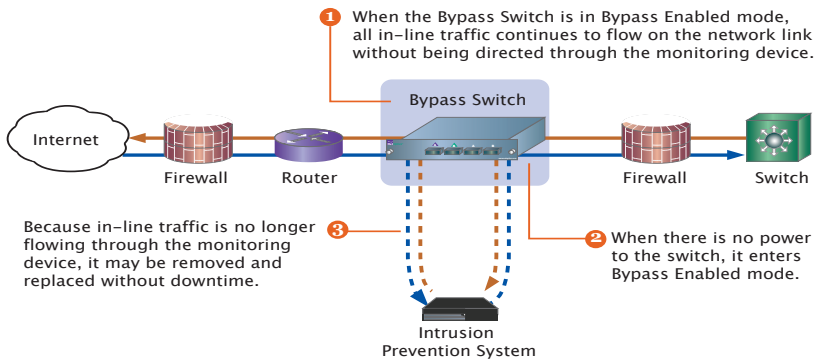

Figure 4. Enabled Mode

Power Loss Bypass (continued)

DC Plug Power Connector Models

The BPO-SX and BPO-LX models use a standard 5 VDC barrel connector and power supply to power the switch.

RJ45 Power Connector Models

The BPO-SX-1 and BPO-LX-1 models use a Control Port with an RJ45 connector to supply power to the switch directly from a source on the in-line device. A control cable with connectors appropriate for your in-line device was provided with the switch. For information on how to connect the control cable to your device, please refer to the documentation for your in-line appliance. For Control Port pinouts, see below.

Control Port Pinouts:

Pin Number	Description
1	Shunt to Pin 2
2	Shunt to Pin 1
3	No connection
4	No connection
5	No connection
6	No connection
7	Ground
8	+5 VDC

Connecting to the Network

1. Connect Network Port A to the appropriate switch, server or router device.
2. Connect Network Port B to the appropriate switch, server or router device.
3. Verify that the Bypass Switch Network Ports are cabled in-line between two devices.

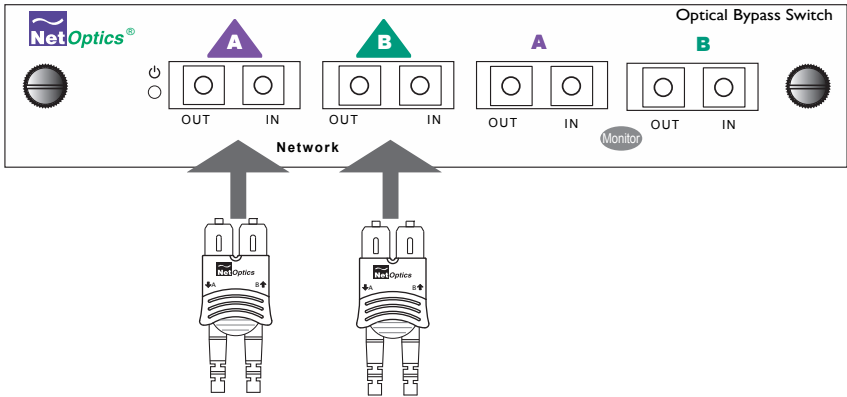

To switch, server, or router (DCE)

Figure 5. Connecting to the Network

Connecting to the In-line Security Device

1. Connect Monitoring Port A to the in-line appliance Port A using a duplex SC fiber cable.
2. Connect Monitoring Port B to the in-line appliance Port B using a duplex SC fiber cable.
3. Verify that the Switch Monitoring Ports are cabled in-line between two devices.
4. Connect the control cable or power supply to the switch. If you are installing the models BPO-SX and BPO-LX, make sure you connect the switches' power supply to the same power sources that in-line appliance is using.

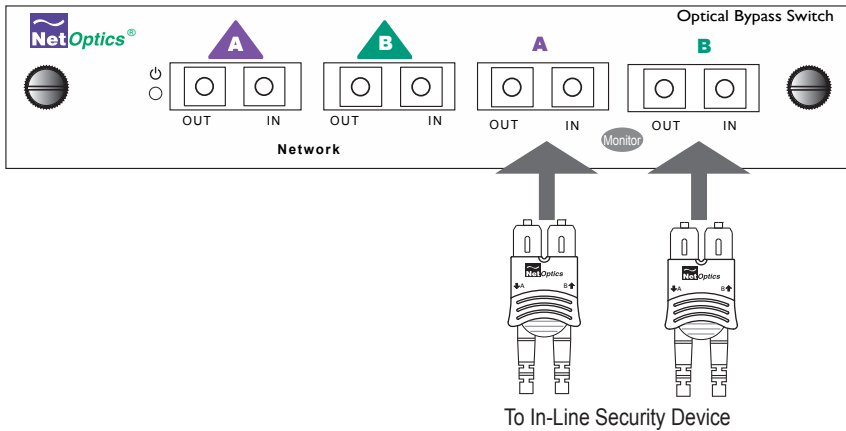

Figure 6. Connecting to the Monitoring Device

Specifications

Splitter Specifications

Fiber Type: Multimode Corning 62.5/125 μ m, wavelength, 850nm
Insertion Loss: Network Port: ≤ 1.25 dB
Monitor Port: ≤ 1.25 dB

Fiber Type: Singlemode Corning 8.5/125 μ m, wavelength, 1300nm
Insertion Loss: Network Port: ≤ 1.25 dB
Monitor Port: ≤ 1.25 dB

Note:

There is no insertion loss when the switch is not receiving power and is in Bypass OFF mode.

Environmental

Operating Temperature: 0°C to 40°C
Storage Temperature: -10°C to 70°C
Relative Humidity: 10% min, 95% max, non-condensing

Power

Power Supply: Input Power: 100-250V, 0.5A, 47-63Hz
Output Power: 5V, 2.4A

Mechanical

Dimensions: 1.125" high x 6.0" deep x 6.5" wide

Connectors

BPO-SX and BPO-LX models:

- (2) Duplex SC connectors (monitor ports)
- (2) Duplex SC connectors (network ports)

BPO-SX-1 and BPO-LX-1 models:

- (2) Duplex SC connectors (monitor ports)
- (2) Duplex SC connectors (network ports)
- (1) RJ45, 8-pin connector (control port)

Certifications

Fully RoHS compliant

Limitations on Warranty and Liability

Net Optics offers a limited warranty for all its products. IN NO EVENT SHALL NET OPTICS, INC. BE LIABLE FOR ANY DAMAGES INCURRED BY THE USE OF THE PRODUCTS (INCLUDING BOTH HARDWARE AND SOFTWARE) DESCRIBED IN THIS MANUAL, OR BY ANY DEFECT OR INACCURACY IN THIS MANUAL ITSELF. THIS INCLUDES BUT IS NOT LIMITED TO LOST PROFITS, LOST SAVINGS, AND ANY INCIDENTAL OR CONSEQUENTIAL DAMAGES ARISING FROM THE USE OR INABILITY TO USE THIS PRODUCT, even if Net Optics has been advised of the possibility of such damages. Some states do not allow the exclusion or limitation of implied warranties or liability for incidental or consequential damages, so the above limitation or exclusion may not apply to you.

Net Optics, Inc. warrants this Optical Bypass Switch to be in good working order for a period of ONE YEAR from the date of purchase from Net Optics or an authorized Net Optics reseller.

Should the unit fail anytime during the said ONE YEAR period, Net Optics will, at its discretion, repair or replace the product. This warranty is limited to defects in workmanship and materials and does not cover damage from accident, disaster, misuse, abuse or unauthorized modifications.

If you have a problem and require service, please call the number listed at the end of this section and speak with our technical service personnel. They may provide you with an RMA number, which must accompany any returned product. Return the product in its original shipping container (or equivalent) insured and with proof of purchase.

Additional Information

Net Optics, Inc. reserves the right to make changes in specifications and other information contained in this document without prior notice. Every effort has been made to ensure that the information in this document is accurate. Net Optics is not responsible for typographical errors.

THE WARRANTY AND REMEDIES SET FORTH ABOVE ARE EXCLUSIVE AND IN LIEU OF ALL OTHERS, EXPRESS OR IMPLIED. No Net Optics reseller, agent, or employee is authorized to make any modification, extension, or addition to this warranty.

Net Optics is always open to any comments or suggestions you may have about its products and/or this manual.

Send correspondence to
Net Optics, Inc.
5303 Betsy Ross Drive
Santa Clara, CA 95054 USA
Telephone: +1 (408) 737-7777
Fax: +1 (408) 745-7719
Email: info@netoptics.com/Internet: www.netoptics.com

All Rights Reserved. Printed in the U.S.A. No part of this publication may be reproduced, transmitted, transcribed, stored in a retrieval system, or translated into any language or computer language, in any form, by any means, without prior written consent of Net Optics, Inc., with the following exceptions: Any person is authorized to store documentation on a single computer for personal use only and that the documentation contains Net Optics' copyright notice.

www.netoptics.com